

DORSET AMATEUR RADIO SOCIAL NETWORK

Summer Special

June 2026

www.darsn.co.uk

In this issue:

- Antenna Radiation Take off Angles
- Portable GPS display
- Temperature Control
- Bio of the Month – Mark (M5MKW)
- Echolink Control Interface
- Audio Peak Meter

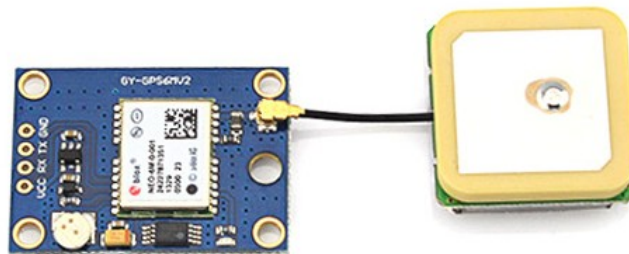

Lindsay - M9LIN
Secretary / Treasurer



Bill - M9WEG
Chairman



Tim – M9WWA
Editor

Events in June

29th May - 1st June
26th June - 29th June

Camperham Weekend
Church Farm Caravan and Camping Park
Salisbury
SP5 5ND

29th June - 5th July
World Wide Sprint Award

See page 5 for more.

Nets

Mondays	No Darsn Net
Tuesdays	145.400 FM
Wednesdays	70.375 FM
Thursdays	Zoom Chat
Fridays	No Net
Saturdays	GB3OF
Sundays	144.375 USB

All details can be found on our Facebook page



Contact Us:

Lindsay
darsn2025@outlook.com
www.darsn.co.uk

Bill
(Via Lindsay)

Tim
admin@wavewizards.org
www.wavewizards.org

Callsign Changes

Peter G0PDF was G0JJI
Lins M9LIN was 2E0VDD
Tim M9WWA was 2E0TPH
Bill M9WEG was 2E0WEG
Mark M9LEG was 2E0VOV
Jon M9VFR was 2E0WJD
Other Callsigns you may hear
David M0KYN (Club Callsign Holder)
Reece M7DVX
Martin M7HQU
Neale M7NED
Dave G7RSD
Glyn M6OVN
Mike G3SED
Ron 2E0JPD
Roger M0RJL

Your Projects Wanted !

Have you got a project that you would like to share with us?

You can submit articles / projects for inclusion here by sending them to the Editor.

Submissions should be tested and be of your own work. We cannot and will not publish anything we feel is Copyrighted material.

Anything is considered.

DARSN NETS!

Mondays	No Darsn Net
Tuesdays	145.400 FM
Wednesdays	70.375 FM
Thursdays	Zoom Chat
Fridays	No Net
Saturdays	GB3OF
Sundays	144.375 USB

No DARSN Net on a Monday BUT, you are all welcome to Join in the Monday Evening Net on 145.375MHz (FM) hosted by [Poole Radio Society](#).

Check out the [NETS](#) Page for more details on Nets in the area.

DARSN would like to thank all of our volunteers who give up their time and resources to run the Nets. You are very much appreciated.

Github Repo

Some of you may have noticed that the recent Arduino code has been available for download from the [Wavewizards](#) download section. I have also created a [Github](#) Repository for all of the source code from the newsletters and this will help to keep all of the code in one place and enables me to keep things updated without continually uploading to the Facebook group.

Feedback Wanted

I would really appreciate your feedback in relation to the Newsletter Content. Is there anything I have missed that you would like to see?

Due to space constraints there has to be some limits in Article length but some ideas.

Digital Modes – Would you like to see a Digital Modes Page? SSTV RTTY FT8
Popular Circuits for the Ham – Audio Notch Filters and the like?
Space News – ARISS – SSTV and Misc Satellite News?

Please email me your [suggestions](#) to help expand the Newsletter

Other News

Did you know that you can track Satellites (including the ISS) in Wavelog? [click here](#) for more information.

The Buy and Sale section is ready for use. You will need a “Wavewizards” email address (It’s free and we have Anti-Spam measures deployed on the server)

You can view the Newsletter online at the DARSN website
View it on the Official Facebook page.
Previous Editions available at [wavewizards](#)

I have something rather special for this December!
Lots of test equipment projects coming in the later part of the year.

I will be scaling back the content for the Summer so that I can go and enjoy some much needed QRV time.

I came across this link that displays Solar activity and imagery from various Global institutions including:

- NOAA Space Weather Prediction Center (SWPC)
- Solar Dynamics Observatory (SDO)
- Atmospheric Imaging Assembly (AIA)
- Solar Terrestrial Relations Observatory (STEREO)
- Deep Space Climate Observatory (DSCOVR)
- Large Angle and Spectrometric Coronagraph Experiment (LASCO)
- Solar and Heliospheric Observatory (SOHO)
- Lockheed Martin Solar & Astrophysics Laboratory (LMSAL)
- Global Oscillation Network Group (GONG)
- Space Weather Canada
- Australia Space Weather Services (SWS)

<https://www.solarham.com/>

Would anyone be interested in a 10m FM Net? Please let me know.

Bio of the Month – Mark (M5MKW)

Well, late 70's I was a CBer. This was my first foray into radio, which lasted a few years.

In 1995 I started working at the Admiralty Test Establishment at Portland Bill, Dorset and worked with an amateur. He said I should take the test as I wouldn't have any problems with it as I was a "bright lad". Bought the RAE book and took the test really only for the qualification. Early 97, M1EPD was licenced. Hanging around with a group of amateurs in Wyke and the South Dorset Radio Society got interested in linking computers to radios and various transmission modes. Really interested in Slow Scan TV, PSK31, Hellschreiber, RTTY and did a lot of SWL. 1999 the requirement for a 12 wpm morse test was lowered to 5 wpm and a group got together to upgrade to the new licence. Passed the test (my current receiving speed then was about 9-10 wpm), applied for a A/B Licence and got M5MKW (which the Americans call a vanity call as this is my initials).

Ran an internet linked node M5MKW-L for several years using Echolink and IRLP (Internet Repeater Linking Project) a dual mode node.

There was a lack of teaching the relevant licences so Neville M5NEV asked if I would hold training courses if he supplied the venue. Over the years I put over 100 through the foundation, over 40 for the intermediate and 12-15 for the full (advanced) licences.

Enjoyed the special events stations clocking up a lot of hours for Lighthouses, museums, Marconi days, also Barnes Wallis, VE Day,

As usual, life changes and I went QRT for several years but still did some SWL and started to help out at the Norman Lockyer Observatory with the radio astronomy.

The dreaded Covid hit and took that opportunity to blow the dust off the Kenwood 870 (the best transceiver in the world {my opinion}) and started using FT8. Did about 1000 QSO's with the best, Tasmania (confirmed). Re-instated the Kenwood 700 (the second best transceiver in the world {my opinion}) in the car along with the President Lincoln and started a bit if mobile working.

Currently the only thing working is the President Lincoln in the car (bit dusty) as the antenna farm is out of use. Do like the 10 m band, very underutilised. The QTH is a poor one for VHF/UHF so I do struggle with those bands.

Spotted the DARSN and made contact and hence this profile.
May meet up with you all on the air. 73 de Mark, M5MKW

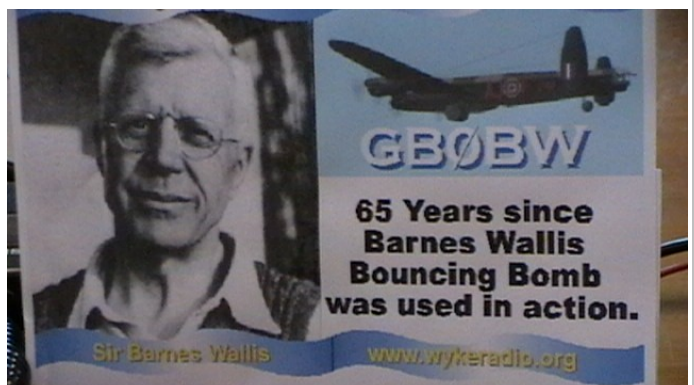

June DX News

Start	End	DXCC	Callsign	QSL Route	Details
1 June	14 June	Lord Howe I	VJ1L	LoTW	By 7 ops; 40-10m, perhaps 80m; CW FT8 SSB; QSL via M0OXO
3 June	12 June	Tanzania	5H1KB	LoTW	By DL2SBY fm Zanzibar I; focus on 6m; QSL via DL2SBY direct
4 June	13 June	Rwanda	9X5KM	LoTW	By F8FUA fm Kigali; HF; CW SSB + digital; 100w; hexbeam, dipoles, verticals; holiday style operation; QSL via F8FUA
8 June	7 July	Tanzania	5H3DX	LoTW	By NK8O fm Dodoma; 40-6m; CW FT8 FT4; 100w; dipole, vertical, longwire
10 June	18 June	Palau	T88AR	LoTW	By JA6UBY fm Koror; 160-6m; FT8 FT4 SSB FM (on 10m); QSL via JA6UBY
10 June	24 June	St Martin	FS	LoTW	By K9EL as FS/K9EL; 80-6m, focus on 6m; CW FT8; QSL via Club Log OQRS
11 June	22 June	St Kitts & Nevis	V47JA	LoTW	By W5JON fm Calypso Bay; 160-6m, incl 60m; SSB FT8; yagi, verticals; QSL also OK via W5JON direct
12 June	29 June	Curacao	PJ2	LoTW	By PH2M as PJ2/PH2M; 80-6m, including 60m; mainly FT8 FT4, some SSB
17 June	24 June	Cape Verde Is	D44EC	LoTW	By EC1A fm Praia, Santiago I; 40-6m; QSL via EC1A
19 June	22 June	Palau	T88TB	LoTW	By JA0JHQ fm Koror IOTA OC-099, P77fi); HF; QRV for All Asian DX CW Contest; QSL via JA0JHQ direct
20 June	22 June	Armenia	EK	DL2JRM (B/d)	By DL2JRM as EK/DL2JRM; CW SSB
27 June	14 July	St Pierre & Miquelon	FP	LoTW	By KV1J as FP/KV1J; 80-6m; SSB CW FT8; QSL via Club Log OQRS or KV1J direct; QRV for IARU contest and CQ VHF Contest
July					
4 July	23 July	Crete	SV9	LoTW	By HB9EMP as SV9/HB9EMP; HF
22 July	14 Aug	South Cook Is	E51KEE	LoTW	By ZL2KE fm Rarotonga I; HF; CW, some SSB; QSL via IK2DUW, Club Log OQRS, eQSL
23 July	8 Aug	Azerbaijan	4K	LoTW	By DL4XT as 4K/DL4XT fm Baku; 20-10m; SSB CW FT8; 100w; 1/4 wave vertical; QSL via Club Log OQRS

Events Guide

We are planning lots of events for 2026. I will try to dedicate a full page every issue so you can see what's coming up!



CAMPERHAM

WEEKENDS AT CHURCH FARM!

DATES FOR YOUR DIARY 😊

- 29th May – 1st June
- 26th June – 29th June
- 17th July – 20th July
- 28th Aug – 31st Aug

Caravans, campervans and tents welcome – let me know if you can make it 😊🙏

Day visitors are welcome but please consider a £5 donation to the club funds 😊🙏

M9LIN

Camper ham weekend Friday to Monday, nightly charges apply for campers, day visitors are also welcome, but a donation of £5 per day would be welcome to the club funds - free tea and coffee available.



Church Farm Caravan and Camping Park, High Street, Sixpenny Handley, Nr Salisbury, Wiltshire, SP5 5ND

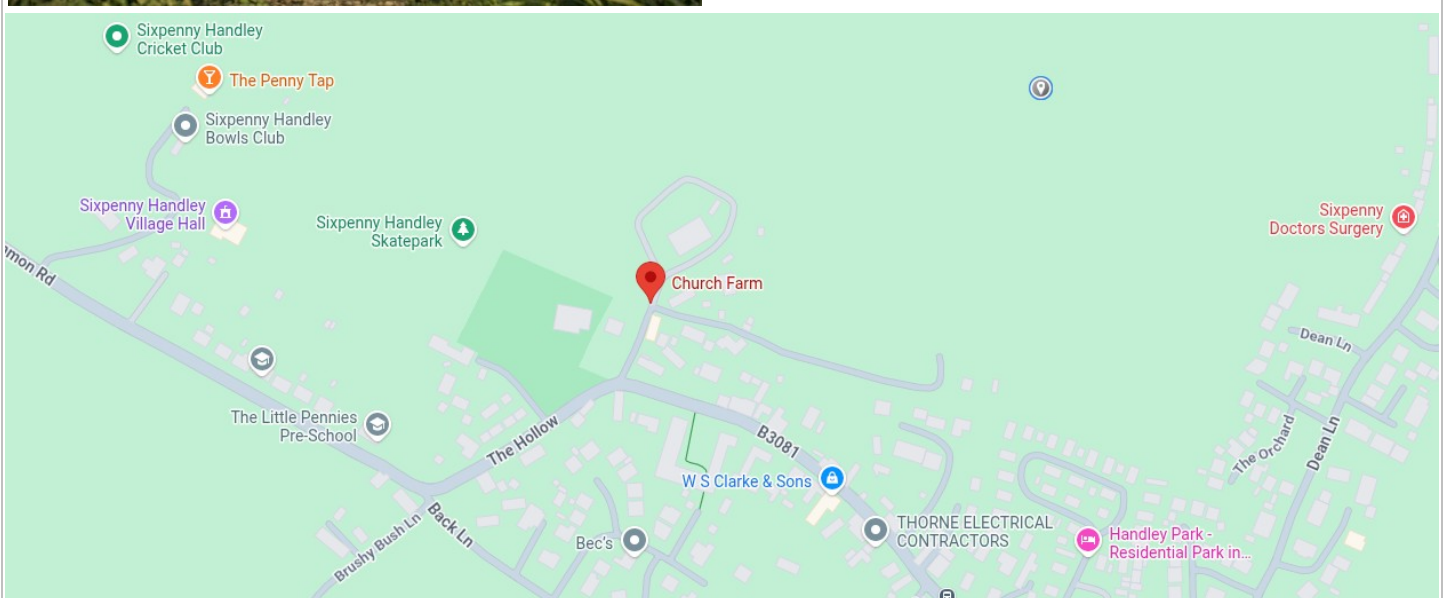

You can find all our Events on our [Facebook Group](#), [Darsn Website](#) or [Wavewizards.org](#)

Past Events

[Three Okefords Preservation Society](#) had their event on the 16th and 17th May. DARSN went along to help promote Amateur Radio and turned up with the two trailers for portable use. A big thanks to Martin (M7HQU) for the blood, sweat and tears that he, and others, has helped to kit out. The trailers are capable of FULL HF coverage with 2m and 4m also taken care of. The White trailer is also equipped with a bed for those wishing to DX overnight, fridge and gas cooker is also supplied. [Note that the Gas Cooker is not used in situ so don't panic – Ed] Everyone had a great time.



Past Events (Continued)



The next event takes place on the 12th July 2026

As usual I (M9WWA) will be QRV from Westbury White Horse in Wiltshire (IO81WG) but this time I will be taking the beam with me and not just the vertical "Whitestick"

Reece (M7DVX) is due to operate from Hardys Monument (IO80rq) on FM

The beam I will be using is a 10 Element (15.1dBi) "OWL" custom made by Vortex. The specs can be seen here: <https://q82.uk/2m10OWL>

If I get the chance, I will make a beam rotator controller as part of an Arduino project. This way I can operate dual polarisation. Do you use a lightweight VHF Rotator? If you do, please drop me an [email](#) and let me know what your solution is.

Contact details are, as always, on the front page.

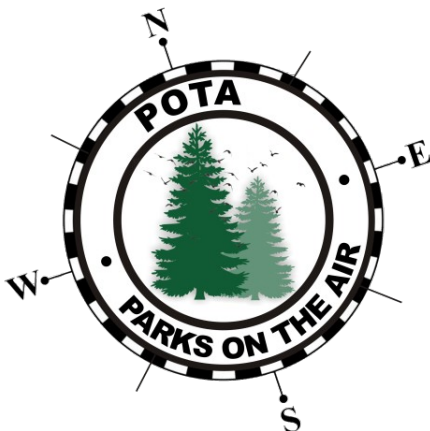

There are normally 5 scheduled events per year.

Winter - 3rd Full Weekend of January. January 16-17, 2027
Spring - 3rd Full Weekend of April. April 18-19, 2026
Summer - 3rd Full Weekend of July. July 18-19, 2026
Autumn - 3rd Full Weekend of October. October 17-18, 2026

First full week of the new year. January 1-7, 2027

Take a look at the Beginners Guide to POTA in this Newsletter.

Past Events (Continued) Camperham Weekend

We had such a blast at the Camperham Weekend. Here are a few of the photos! Lots more to come on the Facebook page shortly. Thank you for such a massive turnout over the weekend. If you didn't get the chance to attend, we do have lots more adventures to come. See you there! [Don't forget to bring Sun Cream - Ed]



Introduction to Arduino – GPS Display

This handy little display enables you to see your Lat / Long and Grid Square in a small portable battery powered unit. This version is one of three, the others will be published later in the year.

What do we need?

1 x Arduino UNO R3 [Below] **or** the Arduino Micro **or** Arduino Nano [Right] Either one will suffice.

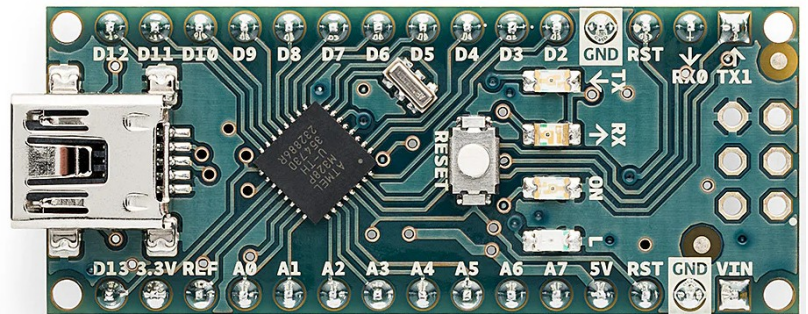
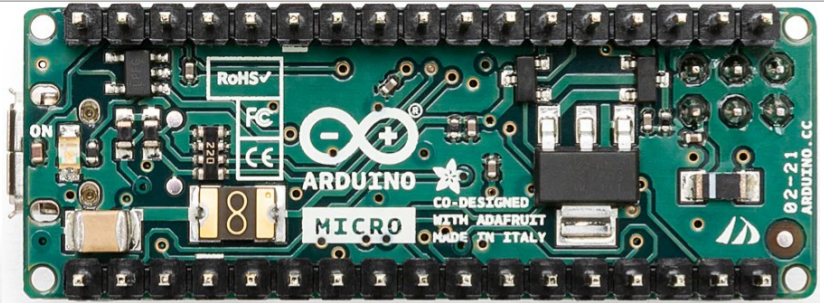
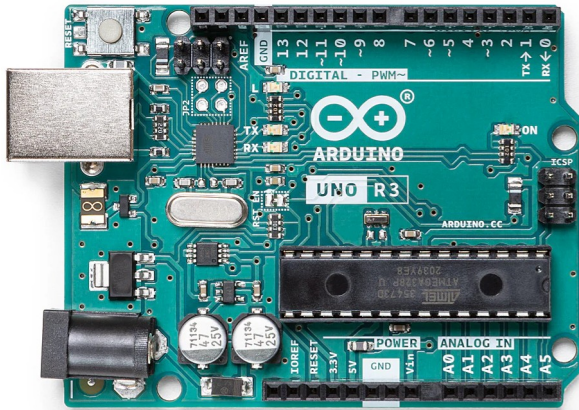

We also need something to display the GPS information on. I have opted for the 16 (Character wide) x 2 (Rows high) known simply as a 16x2 LCD Display. The one I have chosen communicates over the I2C bus as this saves a lot of pins / wiring that we can utilise elsewhere in our project. These displays are available in different colours.

I have chosen the White text on Blue Background. You can chose what you like.

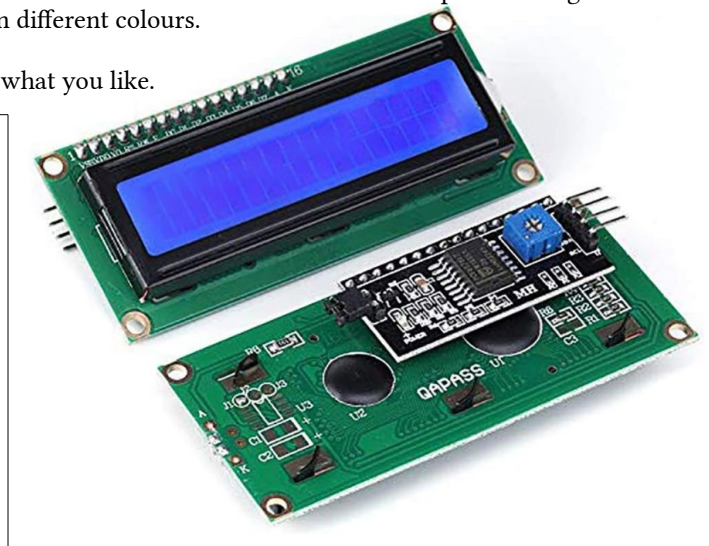
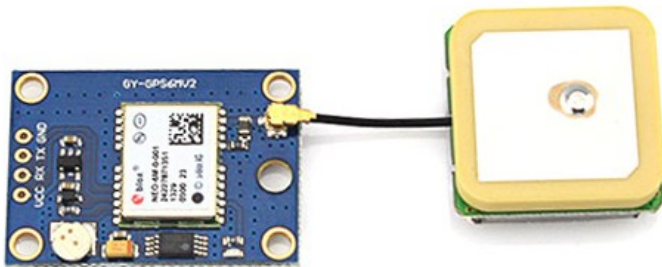

Finally we need to choose a GPS Receiver Module. Any module that outputs a TTL level RS232 UART NMEA sentence will do. I have chosen the NEO-6M

The NEO-6M is discontinued but you will find a LOT of these on eBay and Amazon. Prices should be around £5 per module with the antenna. The Antenna is shown in the above image, note that the Antenna should be positioned as shown for optimal reception of GPS Satellite data. The same applies to the Arduino Nano and Micro. You will find plenty of stock on Aliexpress for around £3 to £6. Sometimes you will find packs of 5 for £10. At these prices, you would be silly to pass it up.

Please note that it is also possible to use a USB to TTL level converter and plug the GPS Module directly to a laptop. This enables you to use applications / programs such as Direwolf, APRS and AGWPE. A truly remarkable device that unleashes the imagination and enables the creation of some rather clever designs. It is only your imagination that is the limit.

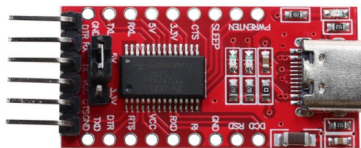

I have run out of time for this edition. The final full schematic and code WILL be a priority for the July Edition. Sorry about that.

55 Years of The 555 Timer IC

The 555 Timer IC was designed in 1971 and reached production in 1972 – Initially made by Signetics

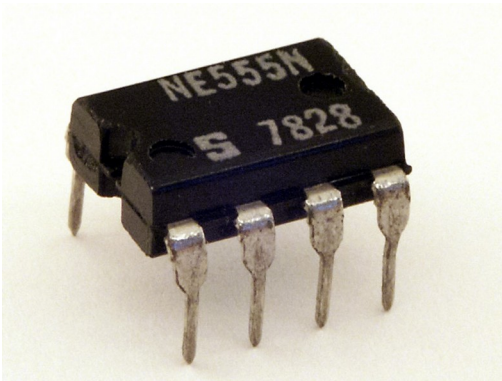

By de:User:Stefan506 - Own work, CC BY-SA 3.0, <https://commons.wikimedia.org/w/index.php?curid=351550>

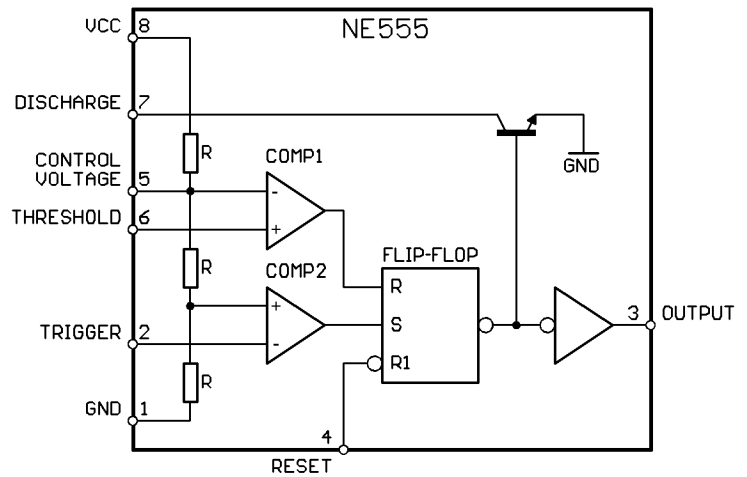

By Own work based on: NE555 astable.png - File:NE555 astable.png, CC BY-SA 3.0, <https://commons.wikimedia.org/w/index.php?curid=9912229>

Silicon die of the first 555 chip (1971)

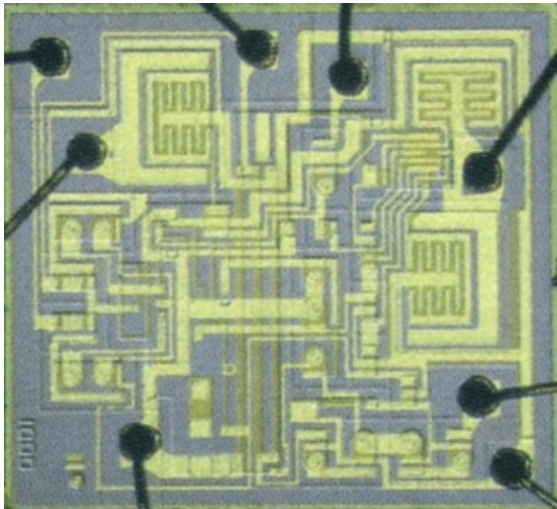

By CQ (CQ Publishing Co., Ltd.) - (in Japanese) Carmenzind, Hans (2010). "IC 555". (Transistor Technology) 47 (12): 74. CQ (CQ Publishing Co., Ltd.. ISSN 0040-9413., Public Domain, <https://commons.wikimedia.org/w/index.php?curid=54506752>

Schematic of a 555 timer in astable mode

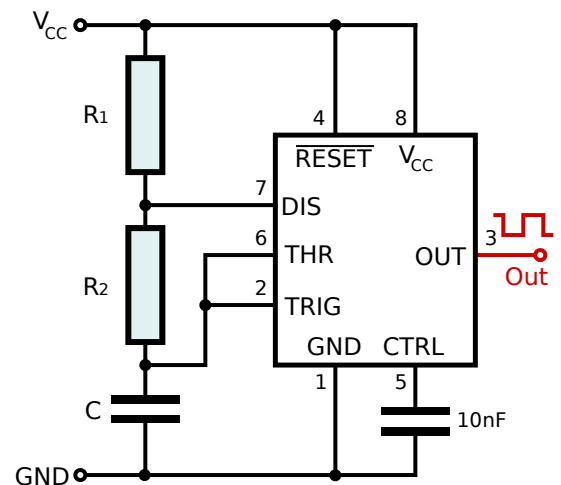

By jjbeard - Own drawing, made in Inkscape 0.43, Public Domain, <https://commons.wikimedia.org/w/index.php?curid=882144>

The above images were used with permission from https://en.wikipedia.org/wiki/555_timer_IC where you can find a wealth of information about the origin's and design of the 555. There are thousands of applications in which you will come across one of these delightful and very versatile chips. The 555 might well be vintage but it still holds it's own and punches above it's class.

There are DIP8 versions and SMD versions, the 555 also comes in a Dual Timer package marked 556 and a Quad Timer Package which you may have guessed is the 558. It is fair to say that I personally have used the 555 and 556 variants but I have yet to come across the 558 in the wild or in commercially available equipment. Standard TTL level devices are available from just about every Chip Manufacturer whilst the CMOS versions are easy to get but very delicate and easy to damage due to ESD Discharge.

If you have not had the chance to play about with a 55, might I suggest you try the following circuit. You can pick up a 555 (pack of 10) for very little cost and the device only requires a few components to get working

555 Timer Circuits

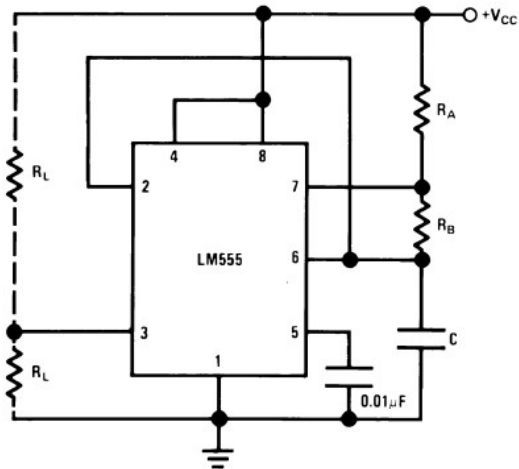

A free running Multivibrator [Left]

If the circuit is connected as shown (pins 2 and 6 connected) it will trigger itself and free run as a Multivibrator.

The external capacitor charges through $R_A + R_B$ and discharges through R_B . Thus the duty cycle may be precisely set by the ratio of these two resistors. Obviously you can control the output by utilising Variable Resistors instead of fixed values.

$V_{CC} = 5\text{ V}$
 Top Trace: Output 5V/Div.TIME = 20 μ s/DIV.
 Bottom Trace: Capacitor Voltage 1V/Div.
 $R_A = 3.9\text{ k}\Omega$
 $R_B = 3\text{ k}\Omega$
 $C = 0.01\text{ }\mu\text{F}$

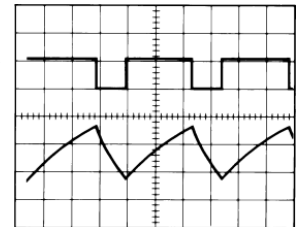

Pulse Generator Circuit

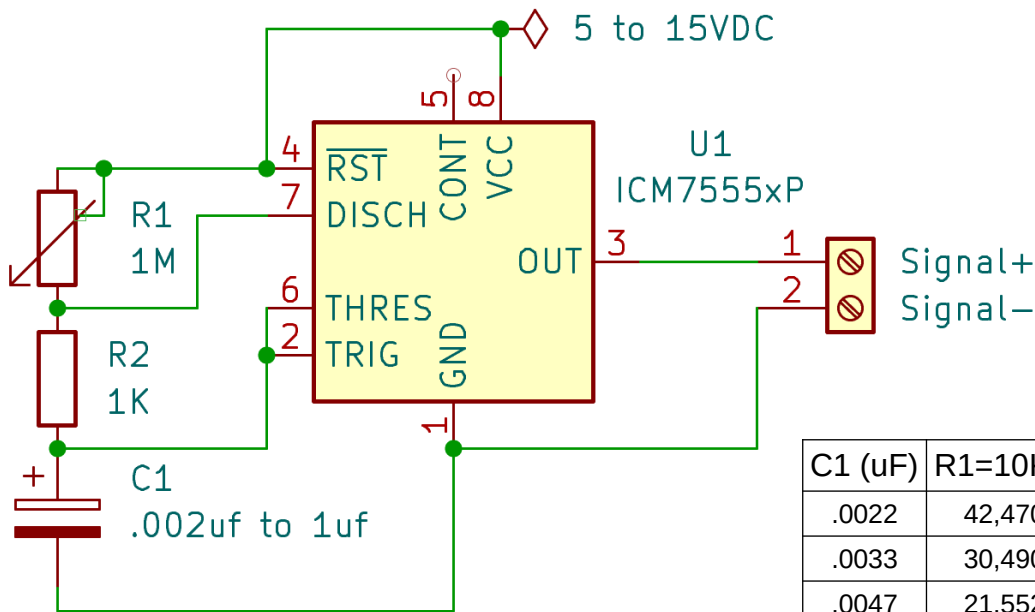

You will need:
 1 x 555 DIP 8 IC (U1)
 1 x Variable Resistor (R1) 1M Ω
 1 x Resistor (R2) 1K Ω
 1 x .002 μ F to 1 μ F (See chart) Electrolytic 16volt Rated

Select your components according to the Generator Frequency you wish to see at the output. You can substitute a Variable Resistor for R2 should you wish to mount on a front panel for easy access.

There is no reason why you cannot use a multi turn (10 turn) pot. That will give you a finer control of the output. Use your imagination to modify the circuit and couple the output to an Oscilloscope or frequency counter to check the output.

I am a great believer of experiment and learn.

C1 (μ F)	R1=10K Ω	R1=100K Ω	R1=1M Ω
.0022	42,470	5,240	520
.0033	30,490	3,740	371
.0047	21,552	2,630	261
.0068	16,300	1,987	197
.01	11,622	1,414	140
.015	7,210	876	87
.022	4,959	601	60
.033	3,530	428	42
.047	2,351	285	28
.068	1,737	210	20
.1	1,139	138	14
.15	804	97	10
.22	540	65	6

Echolink / Digital Modes Interface

Lets start with a basic isolated Digimodes Audio interface. This schematic does not have PTT control. One advantage of using a separate USB interface is that it makes life easier when configuring where the audio is coming from and where it is intended to go. Your volume / Record levels are easier to monitor with the built in Potentiometers. I often build these interfaces into small tins, it just so happens we [sell those in the shop...](#) Depending on what radio you are interfacing with, you could also connect up an APRS or Echolink gateway. It is only audio after all. So what about PTT control?

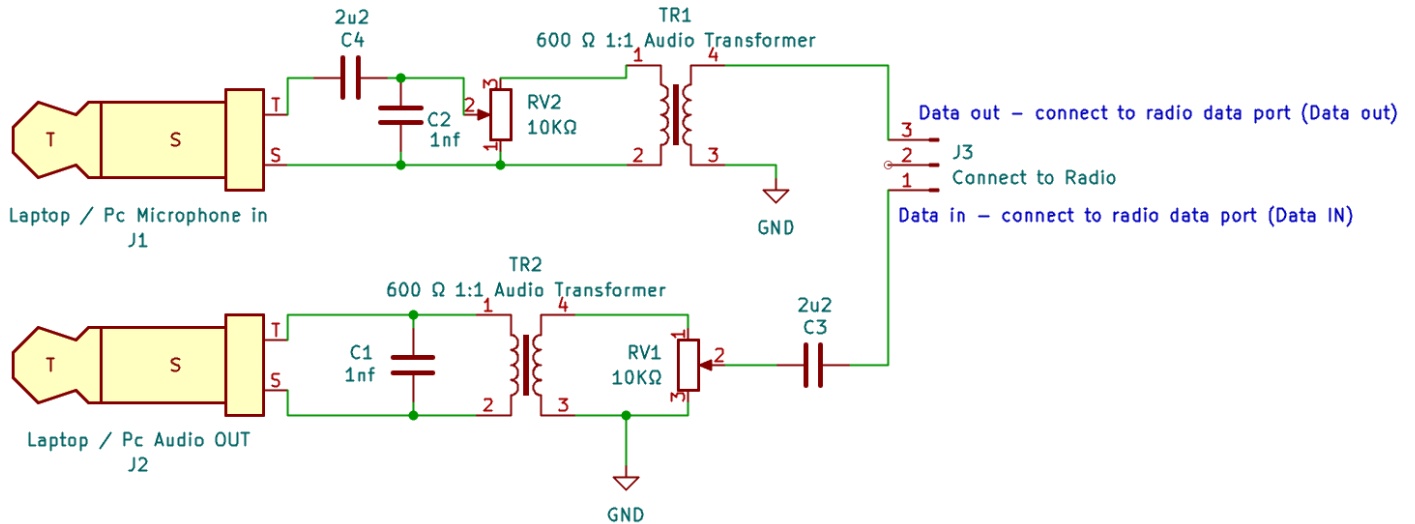

PTT Control can be managed in many different ways. You can even use the circuit in last months Newsletter to activate PTT with an RF Signal but it is widely accepted to use RTS signalling where possible. You could use VOX too but one disadvantage is that the Transmitter might miss the first part of any data you send due to Latency, the time it takes for the Data to reach the Transmitter and the time it takes the Transmitter to engage. This is why we prefer not to use VOX. You can use the RTS line on an older PC / Serial port to control PTT. I will cover USB PTT controls in a later Newsletter along with the CM108 Interface.

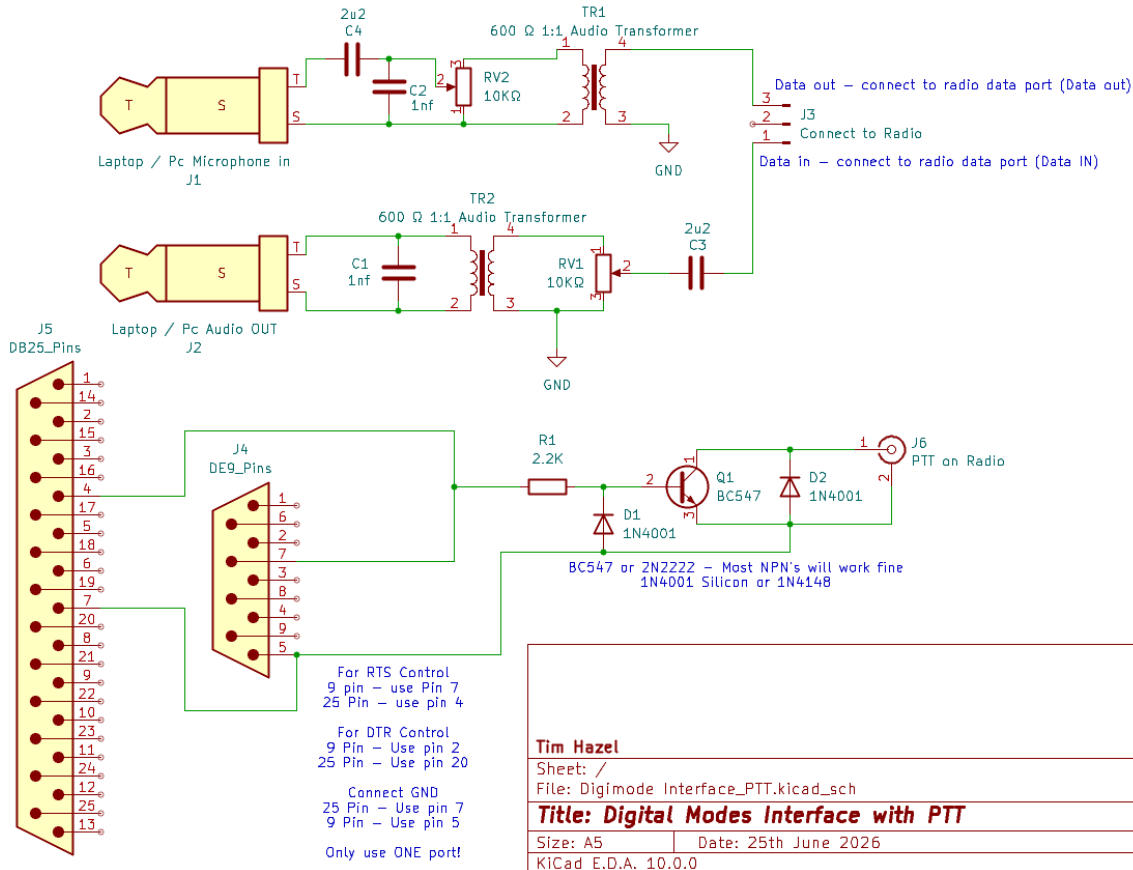

Tim Hazel

Sheet: /

File: Digimode Interface_PTT.kicad_sch

Title: Digital Modes Interface with PTT

Size: A5 Date: 25th June 2026

Rev: 3.2.5

KiCad E.D.A. 10.0.0

Id: 1/1

A Beginners Guide to POTA

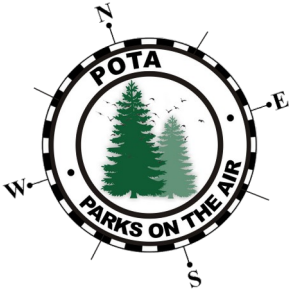

What is POTA?

POTA refers to "Parks on the Air" and has been around for some time. Each place of interest, normally a National Park or landmark is given a POTA Reference number.

You can contribute as a "Hunter" or "Activator"

A Hunter will Hunt the Activators and ideally make a contact with them.

An Activator will sit on a spot frequency and allow the Hunters to make contact.

It is not a contest but it can get quite heated at times.

Here along the South Coast of England we have an abundance of Sites (Yellow Dots)



To check what is available in your region, please go to <https://pota.app/#/map> You can collect awards for certain milestones and activities. A more exhaustive introduction can be found online at <https://docs.pota.app/>

Time	Call	Band	Location	Time Ago
11:09z	14.295 LB1LJ	20m SSB	US-10227: IN - Coastal Plain Ponds State Nature Preserve	1m ago
11:33z	14.305 DL7WBN/P	20m SSB	US-1139: CA - Chino Hills State Park	7m ago
11:36z	14.318 OE8DDX	20m SSB	US-4621: FL - Four Creeks State Forest	3m ago
11:38z	14.282 EA7/MW0JHC	20m SSB	US-6194: WY - False Parting of the Ways BLM Interpretive Site	6m ago
11:50z	14.250 SP1865JML	20m SSB	DE-1051: BY - Irtenerber und Guttenberger Wald Flora and Fauna Reserve	6m ago
11:55z	14.318 DK5CR	20m SSB	US-6609: NJ - Pinelands Preserve National Conservation Area	1m ago
Today	5 QSOs			
15:43z	14.250 YT3IN	20m SSB	US-1829: FL - Alafia River State Park	8s ago
15:50z	14.270 S57NPM	20m SSB	US-3064: UT - Camp Floyd/Stagecoach Inn State Park	4m ago
15:52z	14.305 CT2KNS/P	20m SSB	US-4162: IN - Mounds on Brookville Lake State Recreation Area	2m ago
16:03z	14.253 Y02E0C/P	20m SSB	DE-0741: SH - Gellinger Birk Nature Reserve	2m ago
16:15z	14.240 EA9KB	20m SSB	US-1829: FL - Alafia River State Park	2m ago

There are normally 5 scheduled events per year.

Winter - 3rd Full Weekend of January.

January 16-17, 2027

Spring - 3rd Full Weekend of April.

April 18-19, 2026

Summer - 3rd Full Weekend of July.

July 18-19, 2026

Autumn - 3rd Full Weekend of

October. October 17-18, 2026

First full week of the new year.

January 1-7, 2027

You can find my Comprehensive guide over at wavewizards.org which will guide you through the entire setup and use process. The Ham2k Polo software that I use can even export directly to a wavelog server so you can take care of your QSL confirmations and send those to Qrz.com, Hrdlog, Clublog, Eqsl and others.

For more information check [out my guide](#)

Audio Peak Meter

This simple to build Audio Peak Meter is surprisingly easy to build. It is based around the 4093 IC – The Datasheet can be found on the Wavewizards Site. <https://service.wavewizards.org/Datasheets/4000/4093.PDF>

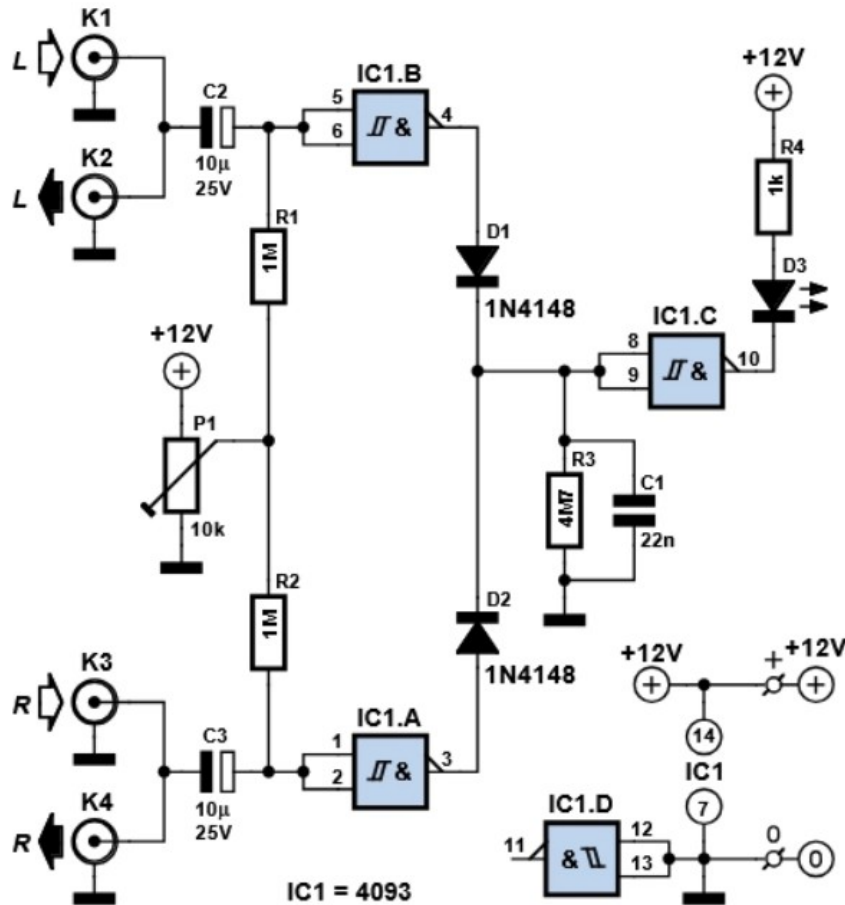

PIN CONNECTIONS

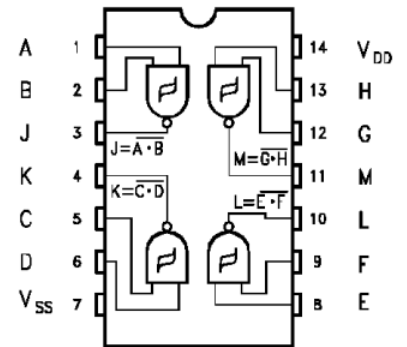

First off, let me say that this schematic was found in the Public Domain and no “Author” or Copyright information was found.

I do not take any credit for someone else’s work and the circuit does seem to work very well. No point re-inventing the wheel, although in a later Newsletter, we can visit Audio Processing as a subject and discuss how Noise Blanker systems work and how Audio Notch Filters can help when dealing with high noise floors on the HF bands.

I have been involved with Analogue and Digital circuits for many years and this is actually quite a simple way of achieving a “Peak” indicator. I am going to set a challenge, if anyone can describe how the circuit works and gets in touch with me with the correct answer, I will offer up a small prize. Not entirely sure what but I will think of something.

We will have a play with some Digital Circuits in the next Newsletter, some basic Frequency Pre-Scalers and Dividers and we will also look at using Logic I.C’s to perform some switching and counting.

We have Take Off!

We often see the phrase "Take Off Angle" being passed around, How many of you understand what it is?

The angle of radiation (or take-off angle) is the elevation angle at which an antenna radiates its strongest signal relative to the ground, and it is primarily determined by the antenna's height above ground rather than the antenna type itself. For horizontal antennas, raising the antenna lowers the radiation angle, with heights around 1/2 wavelength typically achieving the ideal 20° or lower take-off angle required for long-distance DX communication.

Vertical antennas generally produce lower radiation angles than horizontal antennas at the same height, with specific take-off angles depending on their electrical length:

A 1/4 wavelength vertical radiates at approximately 32°

A 3/8 wavelength at 20°

A 1/2 wavelength at 16°

A 5/8 wavelength at 11°.

Key factors influencing the angle of radiation include:

Height: The higher the antenna, the lower the take-off angle; conversely, low antennas (< 1/2 wavelength) radiate at high angles (near 90°) suitable for local coverage but poor for long-distance.

Ground Conductivity: The "magic height" for optimal low-angle radiation varies based on ground quality, with salt water providing the best results and sandy or mountainous terrain requiring higher placement to compensate.

Application: Low angles (< 20°) are essential for DX (long-distance) work to minimize hops through the ionosphere, while high angles are better for NVIS (Near Vertical Incidence Skywave) or local communications.

The relationship for horizontal antennas can be approximated by the formula Angle of Radiation = $\sin^{-1}(0.25 / h)$, where h is the antenna height in wavelengths.

The free space half wave length formula that you should be using is $492/F(\text{MHz})$ not $468/F(\text{MHz})$. This will give you the physical halfwave length. Just take into consideration Velocity Factor of the feedline, you will find the figure in the Manufacturers Datasheet. RG8x is likely to be .68 so $(468/F(\text{MHz}) \times 0.68)$ will give you a better figure to work with. Some will argue that the 468 number is derived from the $492/f(\text{MHz}) \times .96$ which, although technically correct, is not reflective of the actual velocity factor that we need to take into consideration.

Horizontal antennas, such as dipoles or Yagi-Uda, would need to be at heights of 100 ft or more to reach a 10° angle of radiation on the 20-meter band. Such heights are not easily achievable for most stations in the UK. Therefore, 5° radiation is virtually impossible to achieve with horizontal antennas as well.

We can visit Multi-Hop basics in another Newsletter.

In the meantime, you may wish to take a look at this website:

<https://dx-antennas.com/Height%20versus%20take%20off%20angle.htm>

That will give you some further reading on the matter.

LED's to the Rescue

Many older hams enjoy the warm, slightly orange glow of filament lamps inside older Transceivers. Sure, it is nice to have a 4k OLED display on your fresh out of the box big name radio but for many, our passion lays in bringing the older radios back to life.

Many years ago, I [wrote an article](#) on how to substitute a "Grain of Wheat" bulb to a LED. Here we re-visit and go over the basics on what you need to know to change one out during a restoration project.

LED Chart

$$R = (V_s - V_f) / I$$

Resistor required = Supply voltage – Forward voltage / current
Assume 2v forward voltage for standard LED

Supply Voltage = Vs	Current Required (ma)	Resistor Value (Ohms)
3	20	50
5	20	150
6	20	200
8	20	300
10	20	400
12	15	666
12	20	500
12	30	333
24	20	1100
36	20	1700

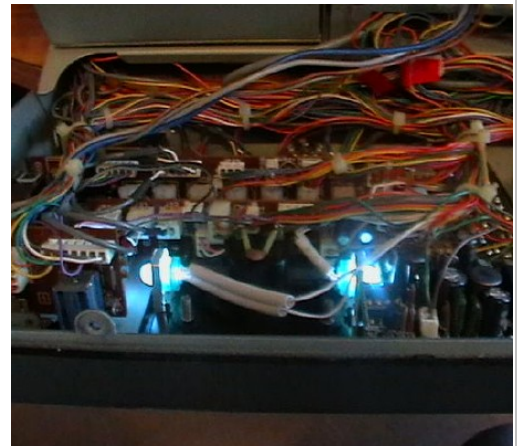

You should always use the next value up. 1700 Ohms would use a 1800 Ohm value as 1700 Ohm resistors do not exist.

Note that it is preferable to use not more than 60% of the resistor wattage rating for safety and reliability purposes.

$$R = (V_s - V_f) / I$$

Vs is the supply voltage to the LED. If you haven't measured the voltage that is going to the old filament lamps, you will find it around 13volts.

Vf is the forward voltage of the LED. This is the amount of voltage required for the LED to actually light.

I is the current that you want to allow through the LED.

R is the value of the resistor in Ohms.

Ok, lets run some figures through that equation. If your mathematical skills are weak please see the chart above in this document.

We know that the LEDs we purchased have a forward voltage of between 1.7 and 2.2 volts. We are going to do both figures and take the middle to be absolutely safe. We also want 20ma to flow through the LED. $R = (V_s - V_f) / I$ becomes $R = (13 - 1.7) / .020$
 $13 - 1.7 = 11.3$ thus $11.3 / .020 = 565$ Ohms.

Now assume 2.2 volts forward voltage so: $R = (13 - 2.2) / .020$ ($13 - 2.2 = 10.8$) so $10.8 / .020 = 540$ Ohms. You would use a 560 Ohm in this application. The lower the value the more current flows and thus brighter the LED. There is a limit though and you should not assume that you have much more than 80ma available. I have used 470 Ohm resistors (x 2) in this document. This seems to be a sensible choice for what we are trying to achieve. Ok, we now know and have the LEDs (x2) and 470 Ohm resistors (x2)



Keep Your Cool!

We are in the Summer Season, the point at which Road Rage drivers come out to play and people get short tempered. Why lose your cool, in fact, why should your equipment suffer from the heat too.

Most electronic parts have a tested rating, this figure is often listed in the Manufacturers Datasheet.

Most Electronic components are good for 85°C but not all! Electrolytic Capacitors come in two temperature classes (Lets ignore the Mil-Spec Version for now), that is 85°C and 105°C. Most Domestic and Commercially targeted components are capable of sustaining heat cycling but that does not mean we can exclude the board from the equation. FR4 (Flame Retardant) PCB's can handle a moderate Thermal Cycling, some older boards cannot. Thermal Cycling can give us some major headache., Solder Joints are susceptible to stress and this can cause some to break or crack. Thermal Transfer Compound can also quickly dry out under harsh conditions leaving what was a "moist" thermal transfer area into a dry and and sometimes crumbly replacement!

It is best to keep things at a cool Ambient Temperature. There are many ways to achieve this. Custom boards can be purchased very cheaply and simply connect to a Fan unit, an on board temperature sensor, Thermocouple or Thermistor monitors the temperature and provides cooling when the require preset threshold is met.

This is where a Thermistor comes into play. Thermistors come in two flavours, NTC and PTC.
NTC = Negative Temperature Coefficient – As the Temperature rises, the Resistance lowers
PTC = Positive Temperature Coefficient – As the Temperature rises, the Resistance Rises



PTC Devices are often found in Multimeters as a protection device, if the device heats up too much, the PTC goes into a Higher Resistance State and reduces the amount of current flowing through into the rest of the circuit.

Here is a handy circuit that employs a NTC Thermistor as a control switch for a 12 volt fan.

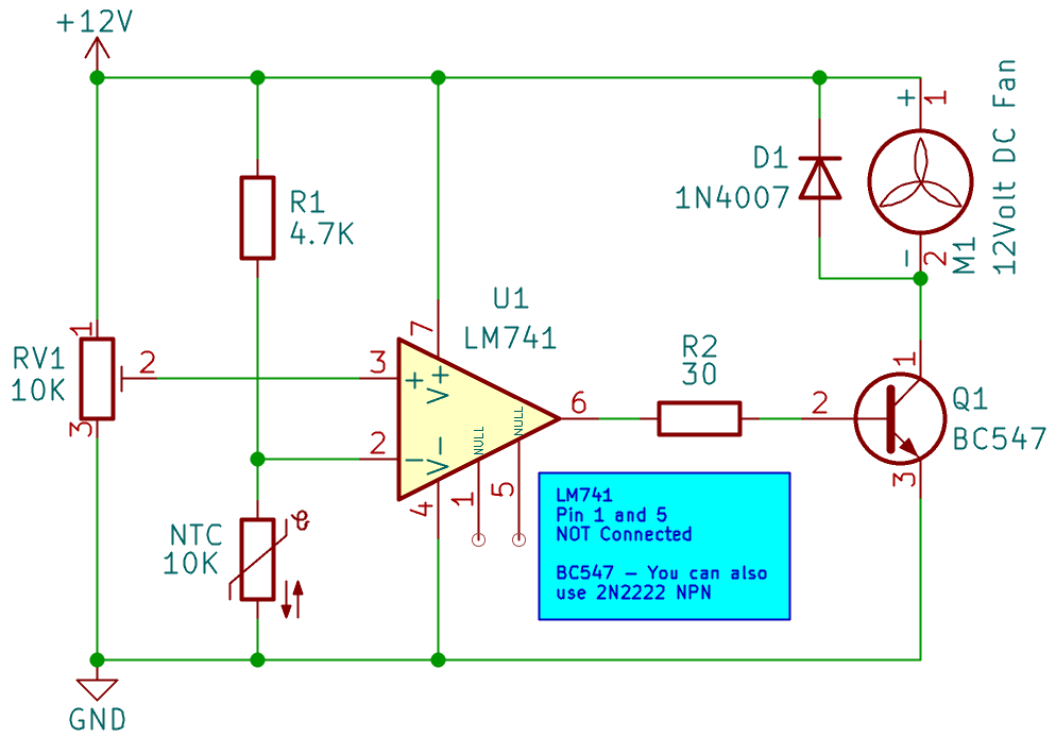

Start by placing RV1 at about halfway. This will make a potential divider threshold value for the Non Inverting input on the LM741. Gently warm up the Thermistor (10k NTC) with either your fingers or the tip of a low wattage soldering iron. Adjust RV1 so that the Fan unit spins up at that required temperature.

You should place the Thermistor against the device you want to monitor. One trick is to drill a small hole in the heat sink you wish to monitor and place the Thermistor in the hole. Use a thermal compound paste to keep the device in situ. You could also use a copper strip to hold the Thermistor in place. You can use a Multimeter to measure the voltage from pin 6 of the LM741. This will ensure that the trigger is working properly. Adjust RV1 accordingly.
We will make an Arduino Temperature logger in a future Newsletter!

June Wordsearch

S	E	R	D	H	X	L	I	R	E	T	A	E	P	E	R	B	Q	V	G	E	Y	G
S	T	U	C	A	L	P	Q	B	V	S	M	W	Z	Y	S	X	E	L	P	U	D	R
Q	S	H	Z	E	R	Y	E	U	L	E	I	E	G	D	Q	V	U	I	O	U	C	O
D	A	E	O	R	L	S	B	W	A	U	S	M	S	M	G	J	G	D	S	Z	C	U
N	M	K	Q	T	V	L	N	A	C	R	E	A	P	H	F	S	O	C	K	Q	A	N
Q	E	K	S	I	S	F	U	D	S	F	T	T	T	L	G	Z	L	R	Y	B	K	D
D	H	W	R	A	X	P	Q	L	M	E	B	E	O	E	E	A	A	W	W	D	I	W
I	M	A	S	O	M	O	O	L	A	E	S	I	R	O	L	X	N	F	A	L	L	A
G	V	E	L	L	U	B	L	T	L	R	G	T	H	W	T	L	A	C	V	E	O	V
I	D	A	E	F	E	T	A	Q	G	A	X	A	A	P	A	H	I	O	E	H	H	E
T	M	B	L	V	W	T	E	I	B	U	L	A	D	T	J	V	Y	T	O	D	E	I
A	M	W	I	O	F	A	T	R	G	W	Q	O	I	V	I	R	E	T	E	N	R	M
L	U	D	B	G	T	D	V	E	S	T	E	L	E	S	C	O	P	I	C	A	T	L
F	R	Q	O	Q	X	B	W	E	R	A	S	U	J	Y	J	K	N	U	A	H	Z	Z
L	X	U	M	D	J	B	Z	T	R	E	H	A	G	E	M	A	N	N	E	T	N	A
O	N	G	V	W	Z	F	R	E	Q	U	E	N	C	Y	N	E	T	W	O	R	K	U

Find the following words in the puzzle.

Words are hidden  and  and  and  and 

ANALOGUE
ANTENNA
BASESTATION
BLUETOOTH
CELLULAR
DARSN
DIGITAL
DUPLEX

FREQUENCY
GROUNDWAVE
HALFWAVE
HANDHELD
HOTSPOT
KILOHERTZ
MAST
MEGADV

MEGAHERTZ
MESH
MMDVM
MOBILE
NETWORK
NEWSLETTER
QUARTERWAVE
REPEATER

ROUTER
RSGB
SATELLITE
SIMPLEX
SKYWAVE
TELESCOPIC

Well, that's this end of the June Newsletter. I hope you have enjoyed this issue.

Coming in the July Edition:

Arduino Temperature Logger

SSTV

Practical Digital Circuits



My sincerest Apologies for having to drop the 2m Amp and the rest of the GPS Display projects.

I will have them completed for the July edition where we will also scale things back a little until

The cooler months of Autumn come along.

Join the [Facebook Group](#) to get the newsletter or view it online <https://www.darsn.co.uk>.

You can also download the archive at www.wavewizards.org/newsletter

As usual, a huge thanks to everyone who go out and participate in events and meet ups.

Until next time, keep those finals warm. 73's Tim [M9WWA - Ed]

[Make a Donation](https://pay.collectiv.com/dorset-amateur-radio-social-network-running-costs-33420) <https://pay.collectiv.com/dorset-amateur-radio-social-network-running-costs-33420>

Lots of merchandise available check out the [website](#) for details, let me know if you would like anything.

Caps, t-shirts, key rings, sweatshirts, hoodies, chopping boards, pens, lanyards, note books, mugs etc

Please get in touch before you order online and ask about payment methods

We are a not for profit club and all proceeds go towards keeping the club going.

Thank you for your support M9LIN

DARSN