

**ICOM<sup>®</sup>**

**SERVICE  
MANUAL**

VHF/UHF FM TRANSCEIVER

**IC-208H**

---

---

---

---

---

---

---

**Icom Inc.**

---

## INTRODUCTION

This service manual describes the latest service information for the **IC-208H** VHF/UHF FM TRANSCEIVER at the time of publication.

MODEL	VERSION	SYMBOL
IC-208H	Taiwan	TPE
	U.S.A.	USA
	Korea	KOR
	Australia	AUS
	Export	EXP

To upgrade quality, any electrical or mechanical parts and internal circuits are subject to change without notice or obligation.

## DANGER

**NEVER** connect the transceiver to an AC outlet or to a DC power supply that uses more than 16 V. This will ruin the transceiver.

**DO NOT** expose the transceiver to rain, snow or any liquids.

**DO NOT** reverse the polarities of the power supply when connecting the transceiver.

**DO NOT** apply an RF signal of more than 20 dBm (100 mW) to the antenna connector. This could damage the transceiver's front end.



## ORDERING PARTS

Be sure to include the following four points when ordering replacement parts:

1. 10-digit order numbers
2. Component part number and name
3. Equipment model name and unit name
4. Quantity required

### <SAMPLE ORDER>

1140005990 S.IC MB15A02PFV-1 IC-208H MAIN UNIT 5 pieces  
8810009610 Screw FH M2.6x6 ZKIC-208H Bottom cover 10 pieces  
Addresses are provided on the inside back cover for your convenience.

## REPAIR NOTES

1. Make sure a problem is internal before disassembling the transceiver.
2. **DO NOT** open the transceiver until the transceiver is disconnected from its power source.
3. **DO NOT** force any of the variable components. Turn them slowly and smoothly.
4. **DO NOT** short any circuits or electronic parts. An insulated tuning tool **MUST** be used for all adjustments.
5. **DO NOT** keep power ON for a long time when the transceiver is defective.
6. **DO NOT** transmit power into a signal generator or a sweep generator.
7. **ALWAYS** connect a 50 dB to 60 dB attenuator between the transceiver and a deviation meter or spectrum analyzer when using such test equipment.
8. **READ** the instructions of test equipment thoroughly before connecting equipment to the transceiver.

---

## TABLE OF CONTENTS

---

<b>SECTION 1</b>	<b>SPECIFICATIONS</b>	
<b>SECTION 2</b>	<b>INSIDE VIEWS</b>	
<b>SECTION 3</b>	<b>DISASSEMBLY INSTRUCTIONS</b>	
<b>SECTION 4</b>	<b>CIRCUIT DESCRIPTION</b>	
4 - 1	RECEIVER CIRCUITS .....	4 - 1
4 - 2	TRANSMITTER CIRCUITS .....	4 - 4
4 - 3	PLL CIRCUITS .....	4 - 6
4 - 4	OTHER CIRCUITS .....	4 - 8
4 - 5	POWER SUPPLY CIRCUITS .....	4 - 8
4 - 6	PORT ALLOCATIONS .....	4 - 9
<b>SECTION 5</b>	<b>ADJUSTMENT PROCEDURES</b>	
5 - 1	PREPARATION .....	5 - 1
5 - 2	SOFTWARE ADJUSTMENTS .....	5 - 3
<b>SECTION 6</b>	<b>PARTS LIST</b>	
<b>SECTION 7</b>	<b>MECHANICAL PARTS AND DISASSEMBLY</b>	
<b>SECTION 8</b>	<b>SEMI-CONDUCTOR INFORMATION</b>	
<b>SECTION 9</b>	<b>BOARD LAYOUTS</b>	
9 - 1	CONTROL UNIT .....	9 - 1
9 - 2	MAIN UNIT .....	9 - 3
9 - 3	VCO BOARD .....	9 - 5
<b>SECTION 10</b>	<b>BLOCK DIAGRAM</b>	
<b>SECTION 11</b>	<b>VOLTAGE DIAGRAMS</b>	
11 - 1	CONTROL UNIT .....	11 - 1
11 - 2	MAIN UNIT .....	11 - 2

# SECTION 1 SPECIFICATIONS

## GENERAL

- Frequency range :

VERSION	RX (MHz)	TX (MHz)
[KOR]	144.000–146.000, 430.000–440.000	144.000–146.000 <sup>*2</sup> , 430.000–440.000
[USA]	118.000–173.995 <sup>*2</sup> , 230.000–549.995 <sup>*4</sup> 810.000–824.000 <sup>*5</sup> , 849.000–869.000 <sup>*5</sup> 894.000–999.990 <sup>*5</sup>	144.000–148.000, 420.000–450.000 <sup>*4</sup>
[AUS]	118–173.995 <sup>*2</sup> , 230.000–549.995 <sup>*3</sup> , 810.000–999.990 <sup>*6</sup>	144.000–148.000, 420.000–450.000 <sup>*3</sup>
[TPE]	144.000–146.000, 430.000–432.000	144.000–146.000, 430.000–432.000
[EXP]	118–173.995 <sup>*2</sup> , 230.000–549.995 <sup>*3</sup> , 810.000–999.990 <sup>*6</sup>	136.000–173.995 <sup>*2</sup> , 400.000–478.995 <sup>*3</sup>

<sup>\*1</sup>Guaranteed 144.000 – 146.000 MHz only, <sup>\*2</sup>Guaranteed 144.000 – 148.000 MHz only,

<sup>\*3</sup>Guaranteed 430.000 – 440.000 MHz only; <sup>\*4</sup>Guaranteed 440.000 – 450.000 MHz only

<sup>\*5</sup>Guaranteed 430.000 – 434.000 MHz, 435.000 – 438.000 MHz only; <sup>\*6</sup>Not guaranteed range

- Mode : FM, AM (AM range is 118.0 – 135.995 MHz and Rx only for [USA] and [EXP].)
- Number of memory channel : 502 (including 2 call channels)
- Usable temperature range : –10°C to +60°C; +14°F to +140°F
- Frequency resolution : 5, 10, 12.5, 15, 20, 25, 30, 50, 100 and 200 kHz
- Scan mode : Full, Program, Priority, Memory channel, Bank, Skip and Tone
- Frequency stability : ±10 ppm (–10°C to +60°C; +14°F to +140°F)
- Power supply requirement : 13.8 V DC ±15 % (negative ground)
- Current drain (at 13.8 V DC) :

		VHF	UHF
TX	High: 55 W <sup>*1</sup> /50 W/25 W <sup>*2</sup>	12 A <sup>*1</sup> /11.5 A/8 A <sup>*2</sup>	11.5 A/8 A
	Middle: 15 W (Approx.)	7.5 A	
	Low: 5 W (Approx.)	5.5 A	5.0 A
RX	Standby	0.8 A	
	Maximum output power	1.0 A	

<sup>\*1</sup>VHF only (except [KOR]), <sup>\*2</sup>[TPE] only

- Antenna connector : SO-239 (50 Ω)
- DATA connector : Mini DIN 6 pin
- Dimensions : 141(W)×40(H)×185.4(D) mm; 5<sup>9</sup>/<sub>16</sub>(W)×1<sup>9</sup>/<sub>16</sub>(H)×7<sup>9</sup>/<sub>32</sub>(D) inch (projections not included)
- Weight : 1.2 kg; 2 lb 10 oz

## TRANSMITTER

- Output power : VHF 55 W (50 W: [KOR], 25W: [TPE])/15 W/5 W (selectable)  
UHF 50 W/15 W/5 W (selectable)
- Modulation system : Variable reactance frequency
- Maximum frequency deviation : ±5.0 kHz
- Spurious emissions : Less than –60 dB
- Microphone connector : 8-pin modular jack (600 Ω)

## RECEIVER

- Receive system : Double-conversion superheterodyne
- Intermediate frequency : 1st IF 46.05 MHz  
2nd IF 450 kHz
- Sensitivity : Less than 0.18 μV (at 12 dB SINAD)
- Squelch sensitivity : Less than 0.13 μV (at threshold)
- Selectivity : More than 12 kHz/–6 dB (Wide); More than 6 kHz/–6 dB (Narrow)  
Less than 30 kHz/–60 dB (Wide); Less than 20 kHz/–60 dB (Narrow)
- Spurious and image rejection : More than 60 dB
- Audio output power (at 13.8 v) : More than 2.0 W at 10% distortion with an 8 Ω load
- External speaker connector : 2-conductor 3.5(d) mm (1<sup>1</sup>/<sub>8</sub>")/8 Ω

All stated specifications are subject to change without notice or obligation.

## SECTION 2 INSIDE VIEWS

### • CONTROL UNIT (TOP VIEW)

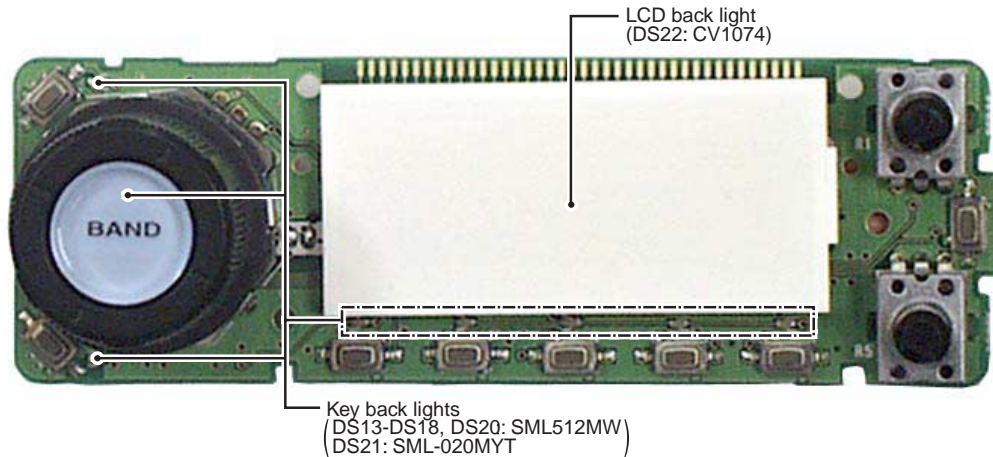

### • MAIN UNIT (TOP VIEW)

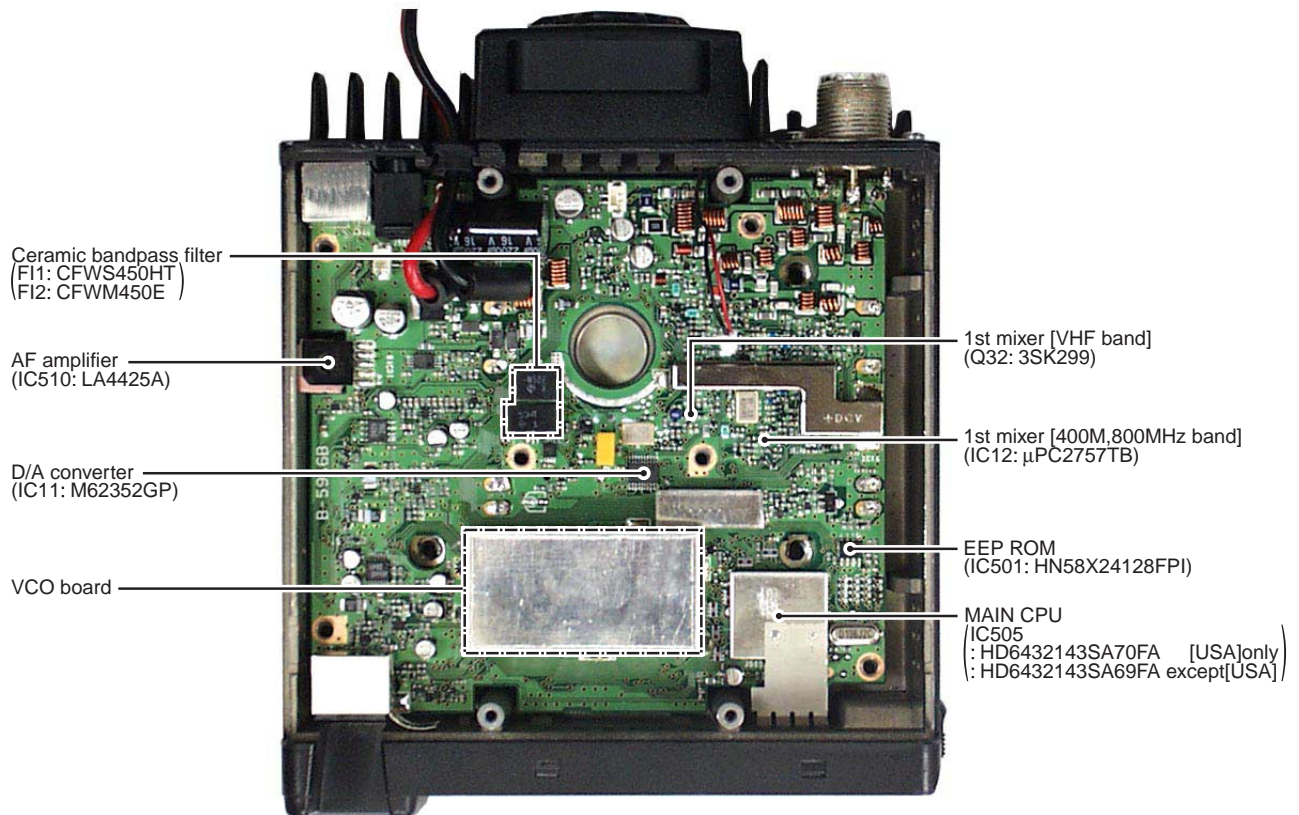

• CONTROL UNIT (BOTTOM VIEW)

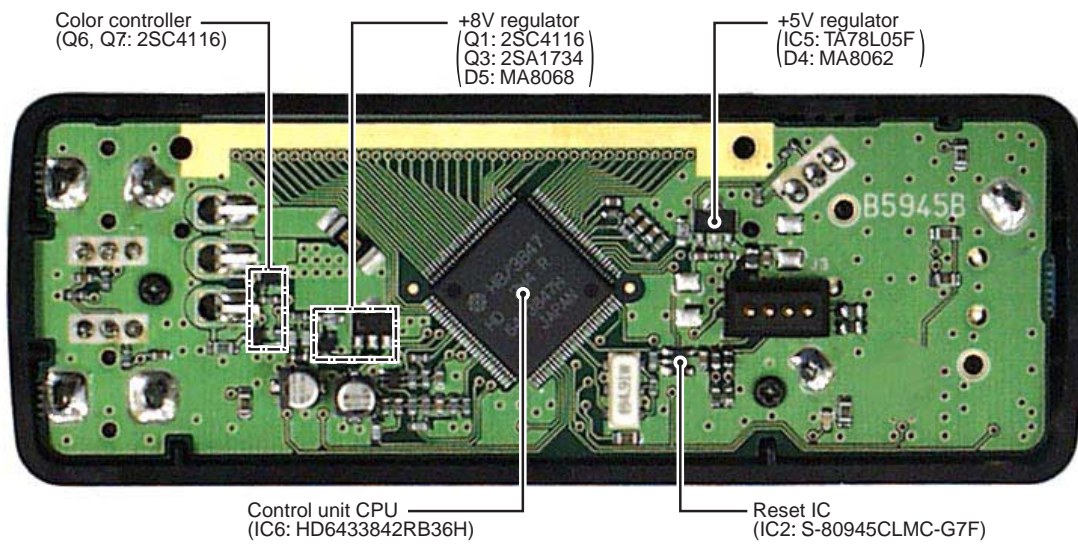

• MAIN UNIT (BOTTOM VIEW)

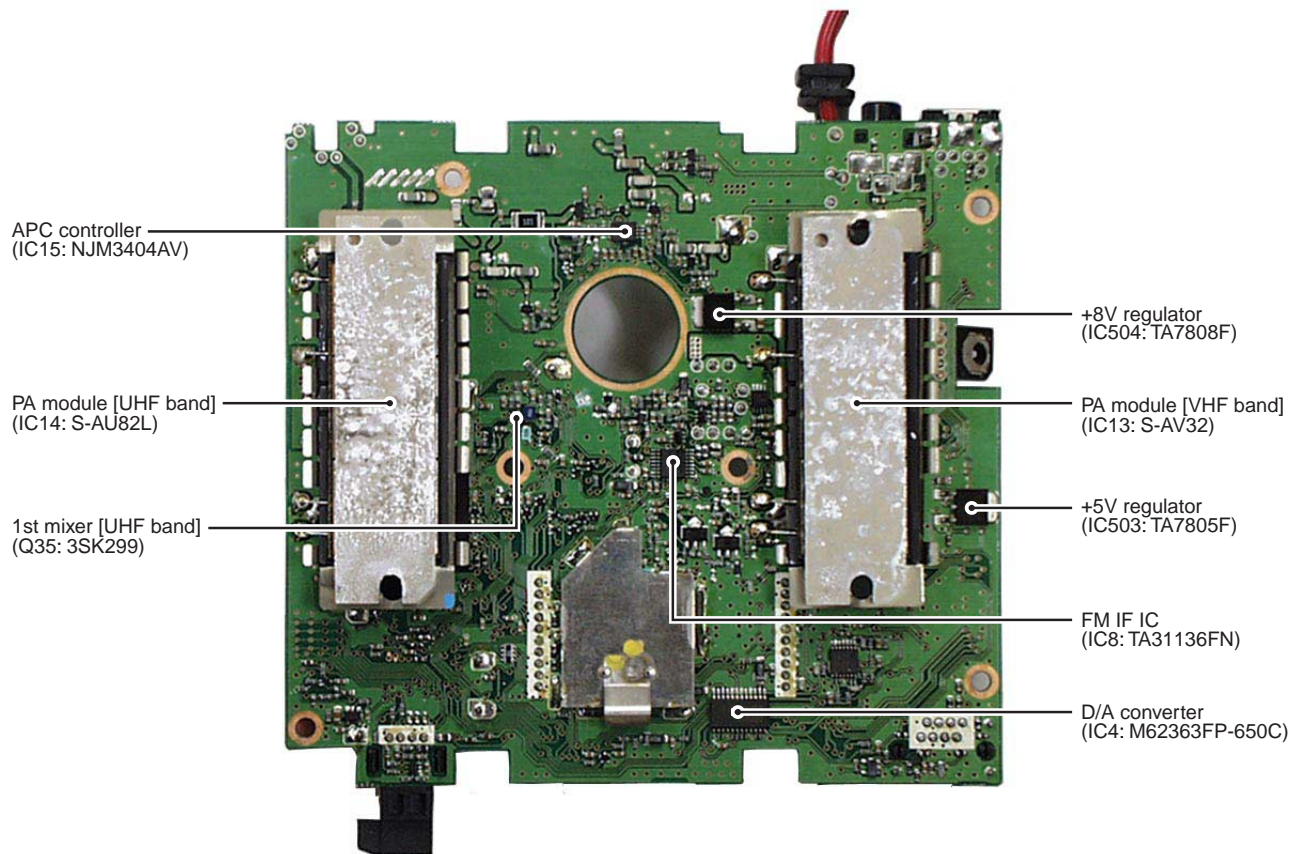

## SECTION 3 DISASSEMBLY INSTRUCTIONS

### • Removing the MAIN unit

- ① Unscrew 4 screws (A), and remove the cover.
- ② Disconnect the cable (B) from J505, and remove the speaker.
- ③ Remove 2 sheets (C).

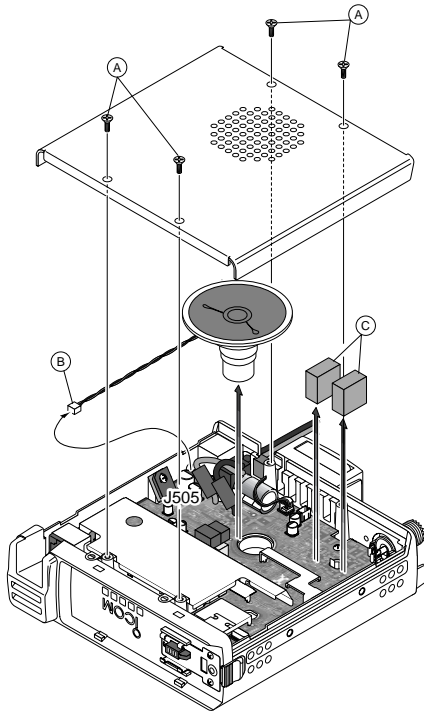

- ⑦ Unscrew 8 screws (G), and remove the MAIN unit.

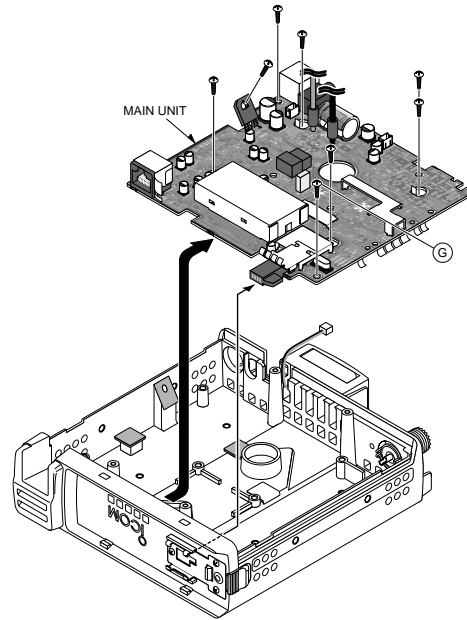

- ④ Unsolder 3 points (D).
- ⑤ Disconnect the cable (E) from J1.
- ⑥ Unscrew 3 screws (F), and remove the cover.

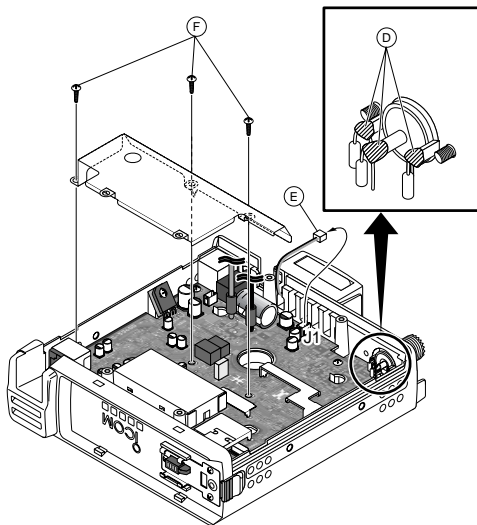

• **Removing the CONTROL unit**

① Remove 2 knobs (A).

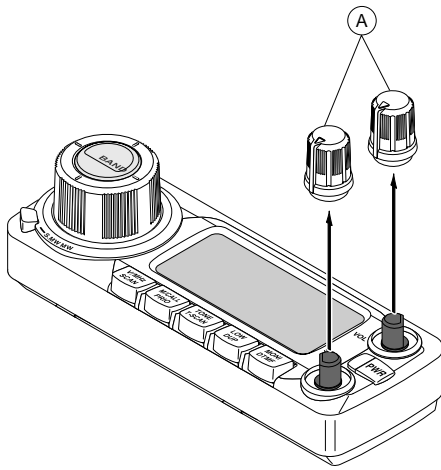

② Unscrew 2 screws (B), and remove the cover.

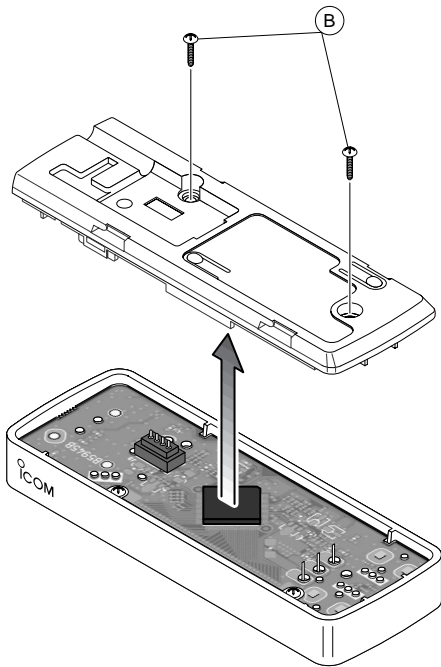

③ Unscrew 2 screws (C), and remove the LCD plate.

④ Remove the CONTROL unit.

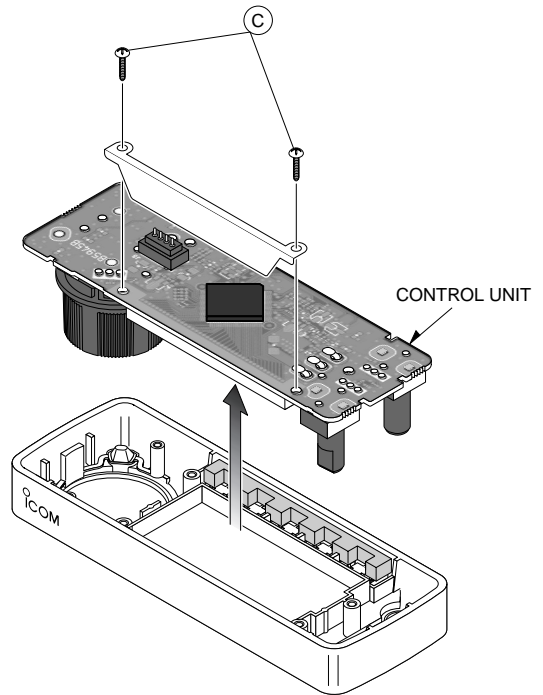

## SECTION 4 CIRCUIT DESCRIPTION

### 4-1 RECEIVER CIRCUITS

#### 4-1-1 DUPLEXER CIRCUIT (MAIN UNIT)

The transceiver has a duplexer (low-pass and high-pass filters) on the first stage from the antenna connector to separate the signals into VHF, UHF and above 800 MHz signals.

The 2 of low-pass filters (L51, L52, L56, C295, C299 and L45, L46, L49, C282, C285, C289) are for VHF signals, the low-pass (L51, L52, L56, C295, C299) and high-pass (L47, L50, C284, C288, C292, C586) filters are for UHF signals and high-pass filter (L55, L58, C298, C302, C304) is for above 800 MHz signals.

The separated signals are applied to each antenna switching circuits (except SHF signals).

#### 4-1-2 ANTENNA SWITCHING CIRCUITS (MAIN UNIT)

The antenna switching circuit functions as a low-pass filter while receiving. However, its impedance becomes very high while transmitting by turning ON diode (VHF: D47, D49, D50; UHF: D46, D48, D51). Thus transmit signals are blocked from entering the receiver circuits. The antenna switching circuit employs a  $1/4\lambda$  type diode switching system.

SHF signals pass through the RX switching circuit (D44).

The passed signals are then applied to the each attenuator circuits.

#### 4-1-3 ATTENUATOR CIRCUITS (MAIN UNIT)

The attenuator circuit attenuates the signal strength to a maximum of 10 dB to protect the RF amplifier from distortion when excessively strong signals are received.

The signals from the antenna switching circuit pass through the each attenuator circuit (for VHF is D49 and D50, for UHF is D46 and D48, for SHF is D39).

The D/A converter outputs "ATT" signal (IC11, pin 6), and is then applied to the attenuator controller circuit (Q44). The circuit output attenuator control signals to each attenuator circuits.

The attenuated signals are applied to the each RF circuits.

#### 4-1-4 RF CIRCUITS (MAIN UNIT)

The RF circuit amplifies signals within the range of frequency coverage and filters out-of-band signals.

##### • VHF RF CIRCUIT (118 MHz–174 MHz)

The signals from the attenuator circuit pass through the tunable bandpass filter (D41, L40, L44, C273, C280). The filtered signals are amplified at the VHF RF amplifier (Q38) and are then enter another 3-stage tunable bandpass filter (D22, D23, D29, L28, C171, C174, C176, C177, C181, C185, C191, C198, C204, C208) to suppress unwanted signals and improve the selectivity. The filtered signals are applied to the VHF 1st mixer circuit (Q32).

##### • UHF RF CIRCUIT (430 MHz–440 MHz)

The signals from the attenuator circuit are applied to the UHF RX switching circuit (D42). The signals are amplified at the UHF RF amplifier (Q39) and are then enter bandpass filter (F14) to suppress unwanted signals. The filtered signals are applied to the UHF 1st mixer circuit (Q35).

#### • RF CIRCUITS

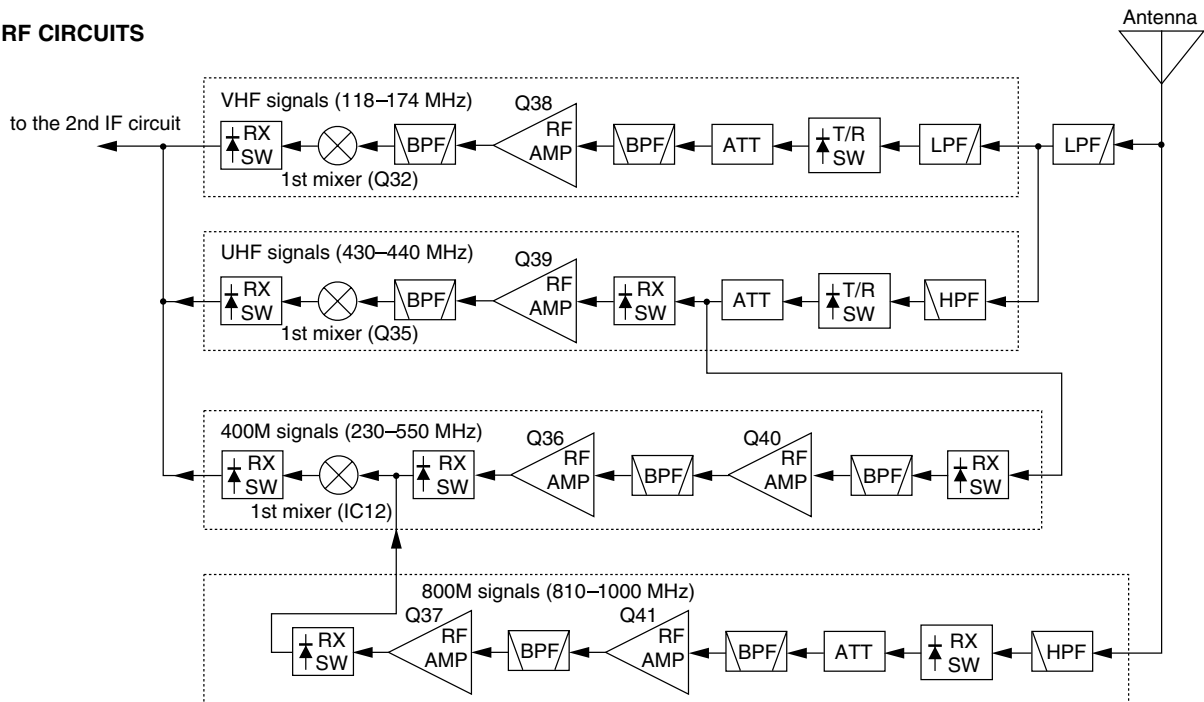

• **ABOVE 230 MHz RF CIRCUIT**

(230 MHz–550 MHz, EXCEPT 430 MHz–440 MHz)

The signals from the attenuator circuit pass through the tunable bandpass filter (D36, L37, L38, C242, C253, C261). The filtered signals are amplified at the above 230MHz RF amplifier (Q40) and are then enter another 2-stage tunable bandpass filter (D25, D30, C205, C212) to suppress unwanted signals and improve the selectivity. The filtered signals are applied to the RF amplifier (Q36). The amplified signals pass through the 400 MHz RX switching circuit (D17), and then applied to the 400 MHz 1st mixer circuit (IC12).

• **ABOVE 800 MHz RF CIRCUIT (810 MHz–1000 MHz)**

The signals from the attenuator circuit pass through the tunable bandpass filter (D37, L39, C243, C254, C260, C269). The filtered signals are amplified at the above 800 MHz RF amplifier (Q41) and are then enter another tunable bandpass filter (D26, D31, L27, L31, C188, C197, C206, C213, C223) to suppress unwanted signals and improve the selectivity. The filtered signals are applied to the RF amplifier (Q37). The amplified signals pass through the 400 MHz RX switching circuit (D18), and then applied to the 1st mixer circuit (IC12) same as 400 MHz RF circuit.

The tunable bandpass filters (D11–D13, D15) employ varactor diodes to tune the center frequency of the RF pass-band for wide bandwidth receiving and good image response rejection.

**4-1-5 VHF 1ST MIXER CIRCUIT (MAIN UNIT)**

The 1st mixer circuit converts the received signal to a fixed frequency of the 1st IF signal with a 1st LO frequency.

• **VHF 1ST MIXER CIRCUIT**

The signals from the VHF RF circuit are mixed with the 1st LO signal at the 1st mixer circuit (Q32) to produce a 46.05 MHz 1st IF signal. The 1st IF signal passes through the RX switching circuit (D8), and are then applied to the 1st IF circuit.

• **UHF (430 MHz–440 MHz) 1ST MIXER CIRCUIT**

The signals from the UHF RF circuit are mixed with the 1st LO signal at the 1st mixer circuit (Q35) to produce a 46.05 MHz 1st IF signal. The 1st IF signal passes through the RX switching circuit (D9), and are then applied to the 1st IF circuit.

• **ABOVE 230 MHz (EXCEPT 430 MHz–440 MHz) 1ST MIXER CIRCUIT**

The signals from the above 230 MHz and above 800 MHz RF circuit are mixed with the 1st LO signal at the 1st mixer circuit (IC12) to produce a 46.05 MHz 1st IF signal. The 1st IF signal passes through the RX switching circuit (D10), and are then applied to the 1st IF circuit.

The output 46.05 MHz 1st IF signals from the each RX switching circuits is applied to the crystal bandpass filter (F13), and then passed through the limiter circuit (D6). The signal is amplified at the IF amplifier (Q18), and then applied to the 2nd mixer circuit (IC8).

**4-1-7 2ND IF AND DEMODULATOR CIRCUITS (MAIN UNIT)**

The 2nd mixer circuit converts the 1st IF signal to a 2nd IF signal. A double superheterodyne system (which converts receive signals twice) improves the image rejection ratio and obtains stable receiver gain.

The FM IF IC (IC8) contains the 2nd local oscillator, 2nd mixer, limiter amplifier, quadrature detector, and noise detector circuits, etc.

The 1st IF signal from the IF amplifier is applied to the 2nd mixer section of IC8 (pin 16), and is mixed with a 45.6 MHz 2nd LO signal generated by the reference oscillator circuit (Q2, Q3, D1, X1) to produce a 450 kHz 2nd IF signal.

The 2nd IF signal from the 2nd mixer passes through the ceramic bandpass filter (passes through F12 during wide channel spacing selection, or passes through F11 during narrow channel spacing selection), where unwanted signals are suppressed. The ceramic filters (F11, F12) are switched by IC9 and IC10 that is controlled by "WN\_SEL" signal from the MAIN CPU (IC505, pin 99).

The filtered signal is applied to the AM or FM detector circuit separately.

• **2ND IF AND DEMODULATOR CIRCUITS**

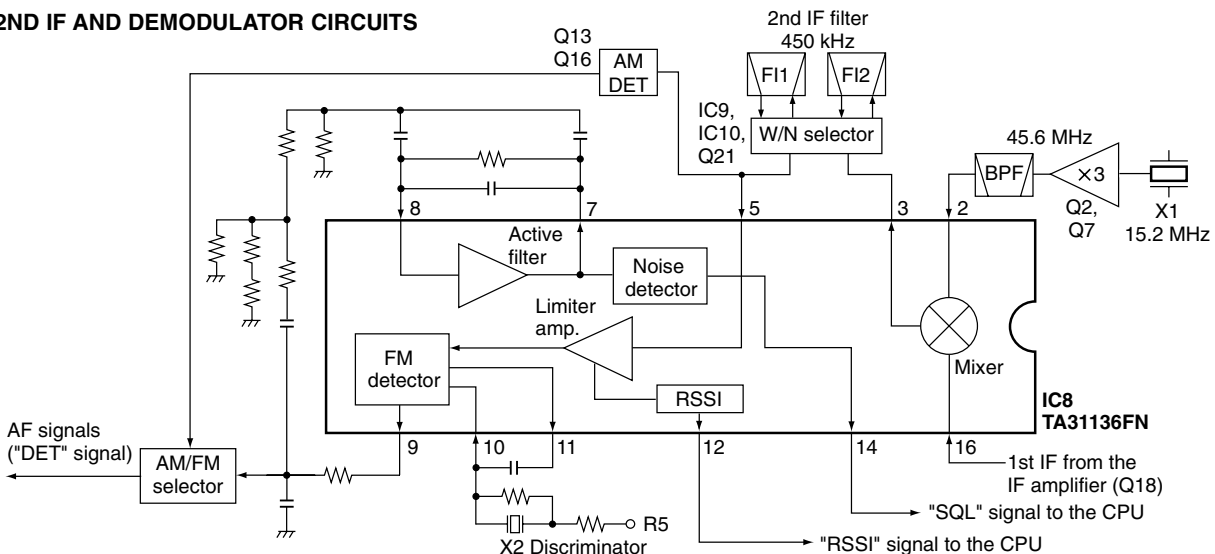

**• IN CASE OF FM SIGNAL RECEIVING**

The signal is then amplified at the limiter amplifier section (IC5, pin 5) and applied to the FM detector section (X2, IC5, pins 10, 11) for demodulation the 2nd IF signal into AF signals.

The FM detector circuit employs a quadrature detection method (linear phase detection), which uses a ceramic discriminator (X2) for phase delay to obtain a non-adjusting circuit. The detected signal from IC5 (pin 9) passes through the AM/FM selector circuit (IC5, pins 7, 1), and is then applied to the AF circuit.

**• IN CASE OF AM SIGNAL RECEIVING**

The signal is amplified at the amplifier (Q16), and is then applied to the AM detector circuit (Q13) for demodulation the 2nd IF signal into AF signals.

The detected signal from Q13 passes through the AM/FM selector circuit (IC5, pins 6, 1), and is then applied to the AF circuit.

**4-1-8 AF AMPLIFIER CIRCUIT (MAIN UNIT)**

The AF amplifier circuit amplifies the detected signals to drive a speaker. The AF circuit includes an AF mute circuit for the squelch.

The detected AM or FM AF signals are applied to AF mute circuit (Q14). The output signals pass through the low-pass filter (Q5), and are then applied to the electric volume circuit (IC508, pin 1). The signals are applied to the other AF mute circuit (Q512). The signals are level adjusted at the volume control IC (IC508), and are amplified at the AF power amplifier (IC510, pin 1) after being passed through the other AF mute circuit (Q512).

The output signal from IC510 (pin 4) drives the external or internal speaker.

A part of signals from the AM/FM selector circuit (IC5, pin 1) pass through low-pass filters.

When the signal passes through the low-pass filter (Q3), the filtered signal is applied to the MAIN CPU (IC505, pin 39) via the "DTCS\_IN" signal to analyze the DTCS signal.

When the signal passes through the other low-pass filter (C52, C53, R46, R52), the filtered signal is applied to the MAIN CPU (IC505, pin 42) via the "WXALT" signal to detect WX alert signal.

A part of signals from the AF mute circuit (Q14) is applied to the 6-pins data jack as data signal via the "DATAOUT" signal.

**4-1-9 SQUELCH CIRCUIT (MAIN UNIT)**

**• NOISE SQUELCH**

A noise squelch circuit cuts out AF signals when no RF signals are received. By detecting noise components in the AF signals, the squelch circuit switches the AF mute switch.

Some of the noise components in the AF signals from the FM IF IC (IC8, pin 9) are passed through the active filter section (IC8, pins 8, 7), and then applied to the noise detector section. The detected noise signals are applied to the MAIN CPU (IC505, pin 38) via the "SQL" line.

Even when the squelch is closed, the AF mute switch (Q512) opens at the moment of emitting beep tone.

**• TONE SQUELCH**

The tone squelch circuit detects AF signals and opens the squelch only when receiving a signal containing a matching subaudible tone (CTCSS). When tone squelch is in use, and a signal with a mismatched or no subaudible tone is received, the tone squelch circuit mutes the AF signals even when noise squelch is open.

A portion of the AF signals from the FM IF IC (IC8, pin 9) passes through the low-pass filter (Q3) to remove AF (voice) signals via the AM/FM AF selector (IC5, pins 7, 1), and is then applied to the CTCSS decoder inside the CPU (IC505, pin 39) via the "DTCS\_IN" line to control the AF mute switch.

**4-1-10 AGC CIRCUIT (MAIN UNIT)**

The AGC (Automatic Gain Control) circuit reduces IF amplifier gain to keep the audio output at a constant level. The receiver gain is determined by the voltage on the AGC line (Q13 collector).

**• AGC CIRCUIT**

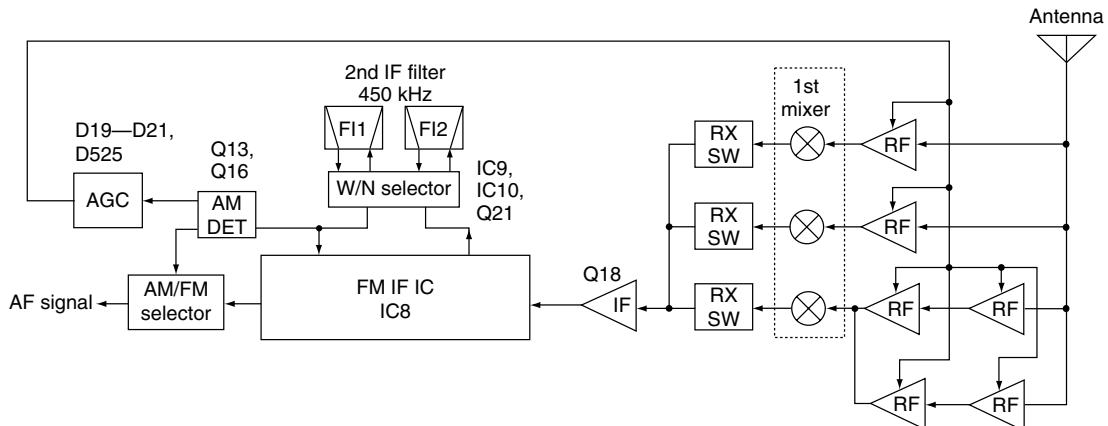

The signal from the AM detector circuit (Q13) is detected at the AGC detector circuit (D19–D21). When receiving strong signals, the detected voltage increases and the AGC voltage decreases via the AGC circuit. The AGC voltage is used for the bias voltage of the receive switching PIN diodes to attenuate the received signals. Therefore, this transceiver keeps the audio output at a constant level.

#### 4-1-11 S-METER CIRCUIT (MAIN UNIT)

The S-meter circuit indicates the relative received signal strength while receiving by utilizing the AGC voltage which changes depending on the received signal strength.

The FM S-meter signal from the FM IF IC (IC8, pin 12) is applied to the main CPU (IC505, pin 40) as an S-meter signal via the “RSSI” signal line.

The S-meter signal is applied to the sub CPU and is then displayed on the LCD.

### 4-2 TRANSMITTER CIRCUITS

#### 4-2-1 MICROPHONE AMPLIFIER CIRCUIT (MAIN UNIT)

The microphone amplifier circuit amplifies audio signals from the microphone to a level needed at the modulation circuit. The microphone amplifier circuit is commonly used for both the VHF and UHF bands.

##### • AUDIO SIGNALS

The AF signals from the microphone are amplified at the microphone amplifier (Q505, IC506), and are then applied to the analog switch (IC509, pin 2). The signals from analog switch (pin 1) are applied to the IDC amplifier (IC3A, pin 3) via the “MODIN” line, and then pass through the low-pass filter (IC3D, pins 13, 14) to suppress unwanted components. IC3A composes limiter amplifier and pre-emphasis circuits.

The signals are amplified at the buffer amplifier (IC3C, pins 9, 8), and are then applied to the D/A converter IC (IC4, pin 13) to adjust modulation level. The signals from the D/A converter (IC4, pin 23) pass through the reference controller (D1, X1), and are then applied to the VHF or UHF modulation circuits separately.

##### • DATA SIGNALS

The data signals from the 6-pins jack (J504, pin 1) pass through the limiter circuit (D524) to limit the level. When setting to 9600 bps mode, The signals pass through the analog switch (IC509, pins 4, 3), and then pass through the switch again (pins 9, 8). The signals are amplified at the buffer amplifier (IC3c, pins 9, 8) via the “DATAMOD” line, and are then applied to the same line as audio signals (applied to the D/A converter IC’s pin 13).

When setting to 1200 bps mode, The signals pass through the analog switch (IC509, pins 4, 3), and then pass through the switch again (pins 10, 11). The signals are then applied to the same line as “MODIN” (applied to the IDC amplifier; IC3A, pin 3).

#### 4-2-2 VHF MODULATION CIRCUIT (MAIN UNIT AND VCO BOARD)

The modulation circuit modulates the VCO oscillating signal (RF signal) using the microphone audio signals.

The audio or data signals from the reference controller (D1, X1) are amplified at the buffer amplifier (Q2), and then pass through the VHF PLL IC (IC1, pins 1,15) and VHF loop filter (IC6, Q9, Q10, D4). The filtered signals are applied to the V-VCO circuit (VCO board).

The signals change the reactance of D1 (VCO board) to modulate the oscillated signal at the V-VCO circuit (VCO board; Q3, D1, D2). The modulated signals are amplified at the buffer amplifiers (VCO board; Q4, Q5), and then passed through the Tx/Rx switching circuit (VCO board; D5) and low-pass filter (L6, C32, C33). The filtered signals are applied to the drive amplifier circuit on the MAIN unit.

##### • TRANSMITTER CIRCUITS

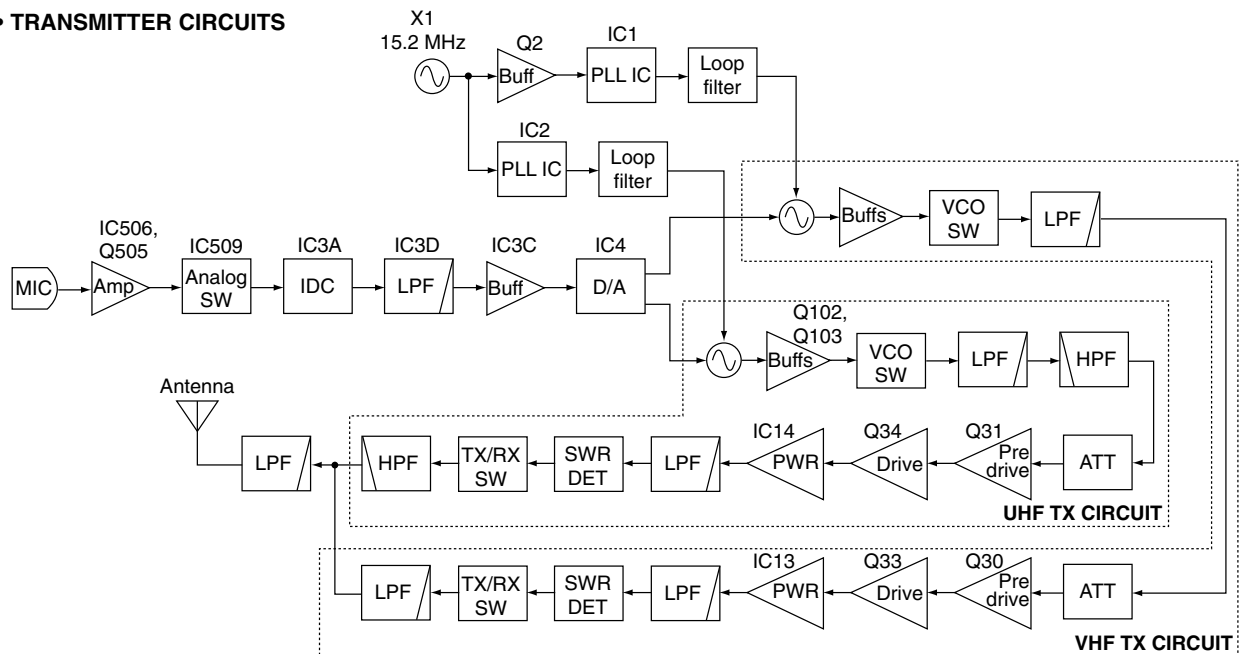

### 4-2-3 VHF DRIVE AMPLIFIER CIRCUIT (MAIN UNIT)

The drive amplifier circuit amplifies the VCO oscillating signal to a level needed at the power amplifier.

The RF signals from the low-pass filter (VCO board) pass through the attenuator (R133, R134, R137), and are then amplified at the pre-drive (Q30) and drive (Q33, D13) amplifiers to obtain power that IC13 can operate. The amplified signal is then applied to the RF power amplifier (IC1).

### 4-2-4 VHF POWER AMPLIFIER CIRCUIT (MAIN UNIT)

The power amplifier circuit amplifies the driver signal to an output power level.

IC13 is a power module which has amplification output capabilities of about 55 W. The RF signal from the drive amplifier (Q33) is applied to IC13 (pin 1).

The amplified signals from the power amplifier (IC13, pin 4) pass through the low-pass filter (L22, C193, C189) and SWR detector (D27, D33), antenna switching circuit (D45) and other low-pass filter (L45, L46, L49, C279, C282, C285, C289). The filtered signals are passed through the low-pass filter (L51, L52, L56, C295, C299) to suppress unwanted signals, and are then applied to the antenna connector (CHASSIS unit J2).

Control voltage for the power amplifier (IC13, pin 2) are controlled by the APC circuit to protect the power module from a mismatched condition as well as to stabilise the output power.

### 4-2-5 VHF APC CIRCUIT (MAIN UNIT)

The APC circuit protects the power amplifier from a mismatched output load and stabilises transmit output power.

The SWR detector circuit (D27, D33, L29) detects forward signals and reflection signals at D27 and D33 respectively. The combined voltage is at a minimum level when the antenna impedance is matched at 50 Ω and is increased when it is mismatched.

The detected voltage is applied to the APC amplifier (IC15, pin 6) and compared with a reference voltage which is supplied from the CPU (IC505) as a "PCON\_V" D/A control signal.

When antenna impedance is mismatched, the detected voltage exceeds the reference voltage. The output voltage of the APC amplifier (IC15, pin 7) controls the bias voltage of the power module (IC13) to reduce the output power via the APC controller (IC15,).

### 4-2-6 UHF MODULATION CIRCUIT (MAIN UNIT AND VCO BOARD)

The audio or data signals from the reference controller (D1, X1) pass through the UHF PLL IC (IC2, pins 1,15) and UHF loop filter (IC6, Q9, Q10, D4), and are then applied to the U-VCO circuit (VCO board).

The signals change the reactance of D100 (VCO board) to modulate the oscillated signal at the U-VCO circuit (VCO board; Q101, D101, D102). The modulated signals are amplified at the buffer amplifiers (VCO board; Q102, Q103), and then passed through the Tx/Rx switching circuit (VCO board; D103) and low-pass filter (L104, C122, C124). The filtered signals are applied to the drive amplifier circuit on the MAIN unit.

### • APC CIRCUIT

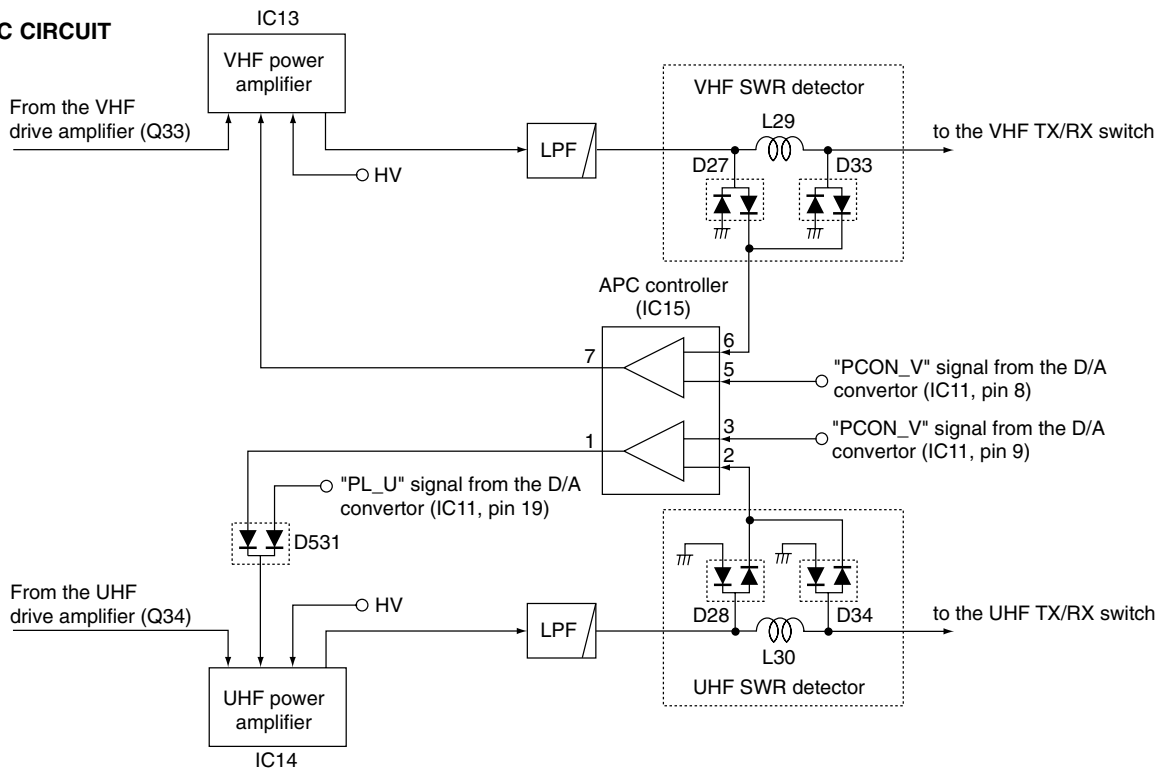

**4-2-7 UHF DRIVE AMPLIFIER CIRCUIT (MAIN UNIT)**

The RF signals from the low-pass filter (VCO board) pass through the high-pass filter (L69, C119) and attenuator (R135, R136, R138), and are then amplified at the pre-drive (Q31) and drive (Q34, D14) amplifiers to obtain power that IC14 can operate. The amplified signal is then applied to the RF power amplifier (IC4).

**4-2-8 UHF POWER AMPLIFIER CIRCUIT (MAIN UNIT)**

IC14 is a power module which has amplification output capabilities of about 50 W. The RF signal from the drive amplifier (Q34) is applied to IC14 (pin 1).

The amplified signals from the power amplifier (IC14, pin 4) pass through the low-pass filter (L23, C190) and SWR detector (D28, D34), antenna switching circuit (D40) and high-pass filter (L47, L50, C284, C288, C292). The filtered signals are passed through the low-pass filter (L51, L52, L56, C295, C299) to suppress unwanted signals, and are then applied to the antenna connector (CHASSIS unit J2).

Control voltage for the power amplifier (IC14, pin 2) are controlled by the APC circuit to protect the power module from a mismatched condition as well as to stabilise the output power.

**4-2-9 UHF APC CIRCUIT (MAIN UNIT)**

The SWR detector circuit (D28, D34, L30) detects forward signals and reflection signals at D28 and D34 respectively. The combined voltage is at a minimum level when the antenna impedance is matched at 50 Ω and is increased when it is mismatched.

The detected voltage is applied to the APC amplifier (IC15, pin 3) and compared with a reference voltage which is supplied from the CPU (IC505) as a "PCON\_U" D/A control signal.

When antenna impedance is mismatched, the detected voltage exceeds the reference voltage. The output voltage of the APC amplifier (IC15, pin 1) controls the bias voltage of the power module (IC14) to reduce the output power via the APC controller (IC15, D531).

**4-3 PLL CIRCUITS**

**4-3-1 GENERAL (MAIN UNIT)**

A PLL circuit provides stable oscillation of the transmit frequency and the receive local frequency. The PLL circuit compares the phase of the divided VCO frequency to the reference frequency. The PLL output frequency is controlled by a crystal oscillator and the divided ratio of the programmable divider. IC1 and IC2 are dual PLL ICs that control both VCO circuits for VHF and UHF.

**4-3-2 VHF LOOP (VCO BOARD AND MAIN UNIT)**

The generated signal at the V-VCO (Q3, D1, D2) enters the PLL IC (MAIN unit; IC1, pin 8) via buffer-amplifiers (Q6, Q8) and VCO switching circuit (D50) and is divided at the programmable divider section and is then applied to the phase detector section.

The phase detector compares the input signal with a reference frequency, and then outputs the out-of-phase signal (pulse-type signal) from pin 15 (MAIN unit).

The pulse-type signal is converted into DC voltage (lock voltage) at the loop filter (MAIN unit; IC5, Q9, Q10, D4), and then applied to the V-VCO to stabilise the oscillated frequency.

**• VHF PLL CIRCUIT**

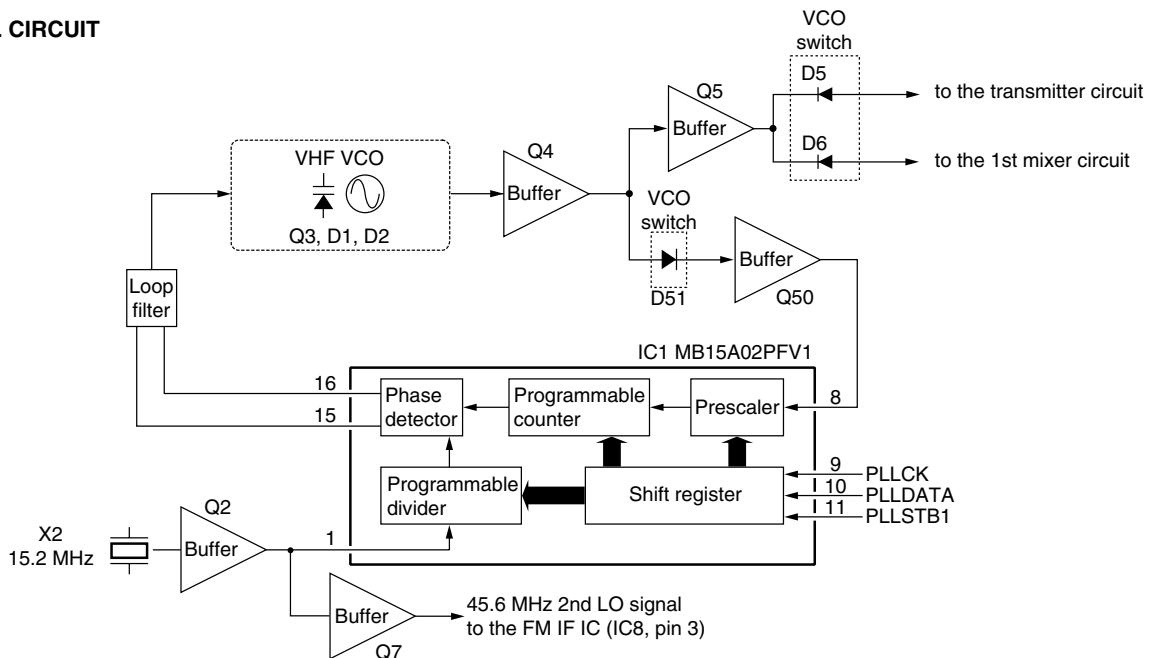

### 4-3-3 UHF LOOP (VCO BOARD AND MAIN UNIT)

The generated signal at the U-VCO (Q101, D100, D101) enters the PLL IC (MAIN unit; IC2, pin 8) via buffer-amplifiers (Q102, Q50) and VCO switching circuit (D51) and is divided at the programmable divider section and is then applied to the phase detector section.

The phase detector compares the input signal with a reference frequency, and then outputs the out-of-phase signal (pulse-type signal) from pin 15 (MAIN unit).

The pulse-type signal is converted into DC voltage (lock voltage) at the loop filter (MAIN unit; IC7, Q11, Q12, D5), and then applied to the U-VCO to stabilise the oscillated frequency.

### 4-3-4 1ST LO CIRCUIT (VCO BOARD AND MAIN UNIT)

The 1st VCO circuit contains a separate V-VCO (Q3, D1, D2) and U-VCO (Q101, D100, D101).

#### • WHILE RECEIVING VHF BAND

The oscillated signal at the V-VCO circuit is amplified at the buffer amplifier (Q4), and is then applied to the VCO switching circuit (D6). The signal passes through the attenuator (C34, R24–R26) and low-pass filter (L7, L8, C36–C38), and is then applied to the LO switching circuit.

#### (1) RECEIVING 118MHz–174 MHz

The signal is applied to the LO switching circuit (MAIN unit; D528) as “V\_RXLO” signal, and is applied to the 1st mixer circuit (MAIN unit; Q32), then mixed with the 1st IF signal.

#### (2) RECEIVING 230 MHz–550 MHz

The signal is applied to the LO switching circuit (MAIN unit; D15, D529, D530) as “V\_RXLO” signal, and is applied to the 1st mixer circuit (MAIN unit; Q35), then mixed with the 1st IF signal.

A portion of the RF signal from the buffer amplifier (Q4) is amplified at the buffer amplifier (Q50) via the VCO switching circuit (D51), and is then fed back to the PLL IC (MAIN unit; IC1, pin 8) as the comparison signal.

#### • UHF PLL CIRCUIT

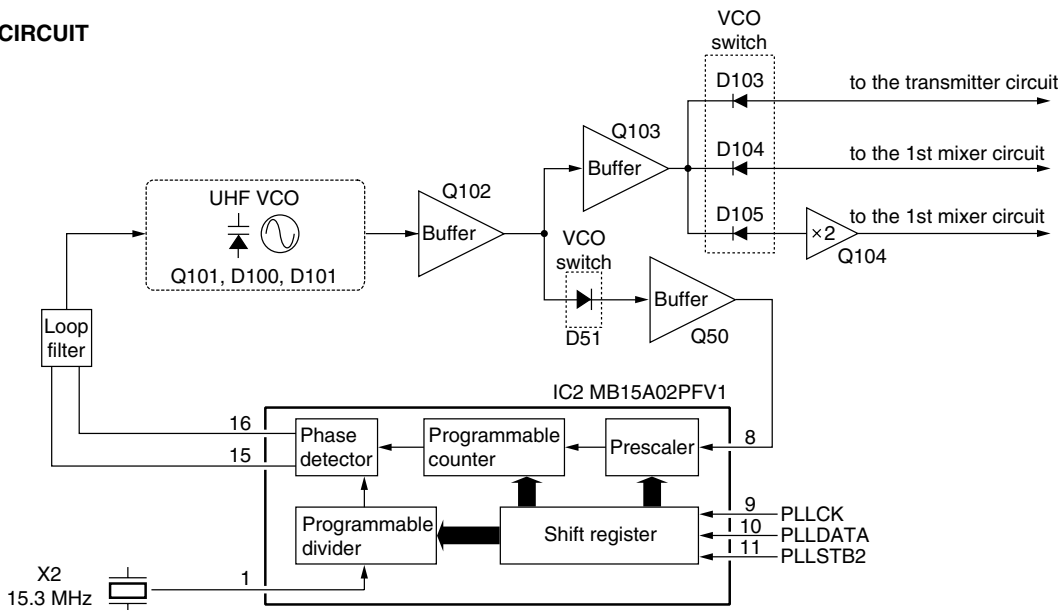

#### • WHILE RECEIVING UHF BAND OR 800 MHz BAND

The oscillated signal at the U-VCO circuit is amplified at the buffer amplifiers (Q102, Q103), and is then applied to the VCO switching circuit (for UHF band; D104, for 800 MHz; D105).

While receiving UHF band, the signal passes through the attenuator (C125, R117, R119, R120) and low-pass filter (Q105, L7, L8, C36–C38), and is then applied to the VCO switching circuit (D106).

While receiving 800 MHz band, the signal is doubled at the doubler amplifier (Q104), and passes through the bandpass filter (L108–L110, C127, C129, C132, C133, C135) and attenuator (R127, R128). The signal is applied to the VCO switching circuit (D107).

#### (1) RECEIVING UHF BAND

The signal is applied to the LO switching circuit (MAIN unit; D9) as “U\_RXLO” signal, and is applied to the 1st mixer circuit (MAIN unit; Q35), then mixed with the 1st IF signal.

#### (2) RECEIVING 800 MHz BAND

The signal is applied to the LO switching circuit (MAIN unit; D10) as “U\_RXLO” signal, and is applied to the 1st mixer circuit (MAIN unit; IC12, pin 6), then mixed with the 1st IF signal.

A portion of the RF signal from the buffer amplifier (Q102) is amplified at the buffer amplifier (Q50) via the VCO switching circuit (D51), and is then fed back to the PLL IC (MAIN unit; IC1, pin 8) as the comparison signal.

## 4-4 OTHER CIRCUITS

### 4-4-1 SUB-CPU RESET CIRCUIT (CONTROL UNIT)

IC2 is the reset voltage detecting circuit. The output voltage from the +5 regulator circuit (IC5) is applied to the VDD terminal (IC2, pin 2). IC2 outputs "H" (high) signal to the sub-CPU (IC6, pin 15) when the VDD terminal's voltage is higher than detecting voltage. IC6 employs the 8-bit CPU.

### 4-4-2 LCD DISPLAY CIRCUIT (CONTROL UNIT)

The transceiver's LCD display employs 1/4 duty custom LCD which displays frequency, S-meter, TX power level, etc. The LCD display is controlled by the sub-CPU (IC6, pins 41-78) directly.

### 4-4-3 LCD AND KEY BACK LIGHT CIRCUIT (CONTROL UNIT)

The sub-CPU (IC6) outputs +8 regulator circuit (Q1, Q3, D5) control signal from pin 2. The voltage from +8 regulator circuit is applied to the key back light circuit (DS13-DS18, DS20, DS23) and LCD back light circuit (DS22).

The back light color is also controlled by the sub-CPU via the color control circuit (Q6, Q7). The back light has 3 colors (Umber, Green and Yellow).

## 4-5 POWER SUPPLY CIRCUITS

### 4-5-1 CONTROL UNIT VOLTAGE LINES

Line	Description
8V	Common 8 V converted from the HV line by the +8 regulator circuit (Q1, Q3, D5). The output voltage is applied to the LCD back light (DS22) and key back light (DS13-DS18, DS20, DS21, DS23) circuits.
CPU5V	Common 5 V converted from the HV line by the +5 regulator circuit (IC5, D4). The output voltage is applied to the reset circuit (IC2) and buffer amplifier (Q2).

### 4-5-2 MAIN UNIT VOLTAGE LINES

Line	Description
HV	The voltage from the external power supply via the W501 (OPC-465).
VCC	The same voltage as the HV line which is controlled by the VCC regulator circuit (Q501). The circuit is controlled by the power switch controller (Q502).
8V	Common 8 V converted from the VCC line by the +8 regulator circuit (IC504).
VT8	Transmit 8 V for VHF band which is the same voltage as the 8V line controlled by the VT8 regulator circuit (Q19, Q22) using the "VTXC" line.
UT8	Transmit 8 V for UHF band which is the same voltage as the 8V line controlled by the UT8 regulator circuit (Q20, Q23) using the "UTXC" line.
5V	Common 5 V converted from the HV line by the +5 regulator circuit (IC503).
5VS	Common 5 V converted from the 5V line by the +5 regulator circuit (Q503, D504). The circuit is controlled by the power switch controller (Q502).
VCO8	Common 8 V converted from the 8 V line by the +8 regulator circuit (Q4).
V_VCO8	Common 8 V line which is selected by the SEL_SW circuit (Q6, Q8). The voltage is applied to the VHF VCO (VCO board; Q3, D1, D2) and buffer amplifiers (VCO board; Q4, Q5).
U_VCO8	Common 8 V line which is selected by the SEL_SW circuit (Q6, Q8). The voltage is applied to the UHF VCO (VCO board; Q101, D100, D101) and buffer amplifiers (VCO board; Q102, Q103).
R5	Receive 5 V line converted from the 5VS line by the R5 regulator circuit (Q24). The circuit is controlled by the "R5CTRL" signal from the CPU (IC505, pin 78).
AM5	Receive 5 V line for AM circuit converted from the 5VS line by the AM5 regulator circuit (Q25). The circuit is controlled by the "AM" signal from the CPU (IC505, pin 69).
VHF_R5	Receive 5 V line for VHF circuit converted from the 5VS line by the VHF_R5 regulator circuit (Q26). The circuit is controlled by the "RXVHF" signal from the CPU (IC505, pin 73).
UHF_R5	Receive 5 V line for UHF circuit converted from the 5VS line by the UHF_R5 regulator circuit (Q27). The circuit is controlled by the "RXUHF" signal from the CPU (IC505, pin 74).
400_R5	Receive 5 V line for 400 MHz circuit converted from the 5VS line by the 400_R5 regulator circuit (Q28). The circuit is controlled by the "RX400" signal from the CPU (IC505, pin 67).
800_R5	Receive 5 V line for 800 MHz circuit converted from the 5VS line by the 800_R5 regulator circuit (Q29). The circuit is controlled by the "RX800" signal from the CPU (IC505, pin 66).

## 4-6 PORT ALLOCATIONS

### 4-6-1 MAIN CPU PORT ALLOCATIONS (MAIN UNIT; IC505)

Pin number	Port name	Description
16	TX_MUTE	Outputs the transmit mute signal. High : While transmit is muting.
17	MIC_PTT	Input port for the microphone PTT signal. High : While PTT switch is pushed.
20	UTXC	Outputs the UHF transmitting power supply circuit control signal. High : While transmitting (400–479 MHz)
21	VTXC	Outputs the VHF transmitting power supply circuit control signal. High : While transmitting (136–174 MHz)
22	DTCS_SEL	Outputs the DTCS filter select signal. High : While the DTCS signal is transmitting.
24	ES_DATA	I/O port for the serial data to the EEPROM (IC501, pin 5).
25	ES_CK	Outputs the clock signal to the EEPROM (IC501, pin 6).
26	P-PTT	Input port for the packet [PTT] switch. Low : While the packet [PTT] switch is ON
27	P_MOD_MUTE	Outputs the packet modulation muting signal. Low : While muting.
28	98_DATA	Input port for the HM-98's data signal.
31	MIC_SEL	Input port for the connecting microphone detect signal. Low : While the HM-98 is connected.
38	SQL	Input port for the squelch level signal.
40	RSSI	Input port for the RSSI signal from the FM IF IC (IC8, pin 12) to detect receiving signal strength.
41	TEMP	Input port for the transceiver's internal temperature signal.
42	WXALT	Input port for the WX alert (1050 Hz) signal.
44	DTMF	Outputs DTMF, E-TONE and BEEP signals.
45	DTCS	Outputs CTCSS and DTCS signals.
47	P_SQL	Outputs the packet squelch control signal. High : While the squelch is opened.
48	FAN_CTRL	Outputs the cooling fan control signal. High : While the cooling fan is worked.
49	CLONE_OUT	Outputs the cloning signal.

### (MAIN unit; IC505)–Continued

Pin number	Port name	Description
50	CLONE_IN	Input port for the cloning signal.
51	DA_DATA	Outputs the data signal to the D/A CONVERTER (IC11, pin 17).
52	DA_CK	Outputs the clock signal to the D/A CONVERTER (IC11, pin 16).
53	DA_STB	Outputs the strobe signal to the D/A CONVERTER (IC1, pin 15).
55	AF_MUTE	Outputs the AF mute control signal. High : While AF signal is muting.
56	PLLSTB2	Outputs the strobe signal to the UHF PLL IC (IC2, pin 11)
57	PLLSTB1	Outputs the strobe signal to the VHF PLL IC (IC1, pin 11)
58	DET_MUTE	Outputs the detector circuit mute signal. High : While the detector circuit is muting.
62	MIC_SENS	Outputs microphone sensitivity control signal. High : The sensitivity is high.
63	U_VCO	Outputs the UHF VCO control signal. High : The VCO circuit oscillates 320–999.99 MHz signal.
65	1200_9600SEL	Outputs packet baud rate select signal. Low : 9600 bps is selected.
66	RX800	Outputs the 800_R5 regulator (Q29) control signal. High : While receiving 630–999 MHz.
67	RX400	Outputs the 400_R5 regulator (Q28) control signal. High : While receiving 230–630 MHz.
72	RXUHF	Outputs the UHF_R5 regulator (Q27) control signal. High : While receiving 430–450 MHz.
73	RXVHF	Outputs the VHF_R5 regulator (Q26) control signal. High : While receiving 118–174 MHz.
74	MMUTE	Outputs modulation mute control signal to the VCO circuits. High : While modulation is muting.
77	MIC_MUTE	Outputs the microphone muting control signal. Low : While the microphone is muted.
78	R5CTRL	Outputs the R5 regulator (Q24) control signal. Low : While receiving.

**(MAIN unit; IC505)–Continued**

Pin number	Port name	Description
79	VCO_SHIFT	Outputs the VCO circuit select signal. High : The VCO circuit oscillates 203.95–263.945 MHz signal.
81	V_VCO	Outputs the VHF VCO select signal. High : The VHF VCO's power supply (Q6, Q8) is ON.
83	PLLSW	Outputs the PLL loop control signal.
84	UNLK	Input port for the PLL unlock signal. High : While the loop is unlocked.
86–89	MATRIX_IN1–IN4	Input ports for the initial matrix signals.
90	PLLDATA	Outputs the PLL data signal to the PLL ICs (IC1, IC2).
91	PLLCK	Outputs the PLL clock signal to the PLL ICs (IC1, IC2).
93–96	OUT1–OUT4	Output the initial matrix strobe signals
99	WN_SEL	Outputs the wide/narrow FM select signal. Low : While selected narrow FM.

**4-6-2 D/A CONVERTER IC PORT ALLOCATIONS  
(MAIN UNIT; IC11)**

Pin number	Port name	Description
2–4	TUNE_V1–V3	Output the VHF bandpass filter tracking signals.
5	TUNE_U	Outputs the UHF bandpass filter tracking signal.
6	ATT	Outputs the receiving attenuator control signal.
7	BSHIFT	Outputs the bandpass filter shift control signal. Low : While receiving 450–629.995 MHz.
8	PCON_V	Outputs the VHF output power control signal.
9	PCON_U	Outputs the UHF output power control signal.
12	TUNE_8	Outputs the 800 MHz bandpass filter tracking signal.
13	REF_CON	Outputs the reference frequency control signal.
18	REF_V	Outputs the excess current detecting signal.

**4-6-3 FRONT CPU PORT ALLOCATIONS  
(CONTROL UNIT; IC6)**

Pin number	Port name	Description
1	BAND	Input port for the [BAND] key. Low : The [BAND] key is pushed.
3	A_LED	Outputs the amber LED control signal. High : The LED lights ON.
4	SMW	Input port for the [S.MW] key. Low : The [S.MW] key is pushed.
5	TONE	Input port for the [TONE] key. Low : The [TONE] key is pushed.
6	LOW	Input port for the [LOW] key. Low : The [LOW] key is pushed.
7	MONI	Input port for the [MONI] key. Low : The [MONI] key is pushed.
8	SET	Input port for the [SET] key. Low : The [SET] key is pushed.
24	M/CALL	Input port for the [M/CALL] key. Low : The [M/CALL] key is pushed.
25	VMHz	Input port for the [V/MHz] key. Low : The [V/MHz] key is pushed.
30	DIAL_A	Input port for the main dial's A phase signal.
31	DIAL_B	Input port for the main dial's B phase signal.
39–42	COM4–COM1	Output the common signals to the LCD (DS1).
43–78	SEG1–SEG36	Output the segment signals to the LCD (DS1).
83	G_LED	Outputs the green LED control signal. High : The LED lights ON.
86	PWR	Input port for the [PWR] key. Low : The [PWR] key is pushed.
88	VOL	Input port for the [VOL] controller.
89	SQL	Input port for the [SQL] controller.

# SECTION 5 ADJUSTMENT PROCEDURES

## 5-1 PREPARATION

Need to enter the adjustment mode, and the JIG cable as shown the page 5-2 is required when adjusting the IC-208H.

### ■ REQUIRED TEST EQUIPMENT

EQUIPMENT	GREDE AND RANGE	EQUIPMENT	GREDE AND RENG
DC power supply	Output voltage : 13.8 V DC Current capacity : 12 A or more	FM deviation meter	Frequency range : 0–600 MHz Measuring range : 0 to ±5 kHz
RF power meter (terminated type)	Measuring range : 0.1–100 W Frequency range : 1.8–600 MHz Impedance : 50 Ω SWR : Less than 1.2 : 1	Oscilloscope	Frequency range : DC–600 MHz Measuring range : 0.01–10 V
		Audio generator	Frequency range : 300–3000 Hz Measuring range : 1–500 mV
Frequency counter	Frequency range : 0.1–600 MHz Frequency accuracy : ±1 ppm or better Sensitivity : 100 mV or better	Attenuator	Power attenuation : 50 or 60 dB Capacity : 150 W or more
Standard signal generator (SSG)	Frequency range : 0.1–1200 MHz Output level : 0.1 μV–32 mV (–127 to –17 dBm)		

### ■ ENTERING THE ADJUSTMENT MODE

- ① Turn the transceiver's power OFF.
- ② Connect the JIG cable to the [MIC] jack.
- ③ Push and hold the [SET] and [BAND] keys, and then turn power ON.

**NOTE:** Exiting from the adjustment mode when the transceiver's power is OFF.

### ■ OPERATING ON THE ADJUSTMENT MODE

- Change the adjustment value : [DIAL]
- Verifying the adjustment value : [M/CALL] key
- Forward the adjustment item : [SET/LOCK] key
- Go back the adjustment item : [S.MW/MW] key
- Store the adjustment value in the memory : [BAND] key

**CAUTION:** Need to push the [BAND] key when storing the adjustment value in the memory. Otherwise, the transceiver is not adjusted properly.

**ATTENTION!:** DO NOT adjust following adjustment items (Because they are adjusted automatically when other adjustment items are adjusted). Otherwise, the transceiver do not work properly. Refer to the next page in detail.

DISPLAY	ADJUSTMENT ITEMS
[Fr1]–[Fr8]	Reference frequency's temp. correction
[rE–], [rE+]	Reference voltage
[PT]	Protect time
[PCV], [PCU]	Protect temperature
[FT]	Cooling fan temperature
[DTA], [DTB]	DTCS wave form
[DT], [CT]	DTCS/CTCSS amplitude
[SL]	*S-Meter
[SqW]	*Squelch level (Wide)
[SqN]	*Squelch level (Narrow)

**NOTE:** \*Need to adjust about manually adjustment items.

## CONNECTIONS

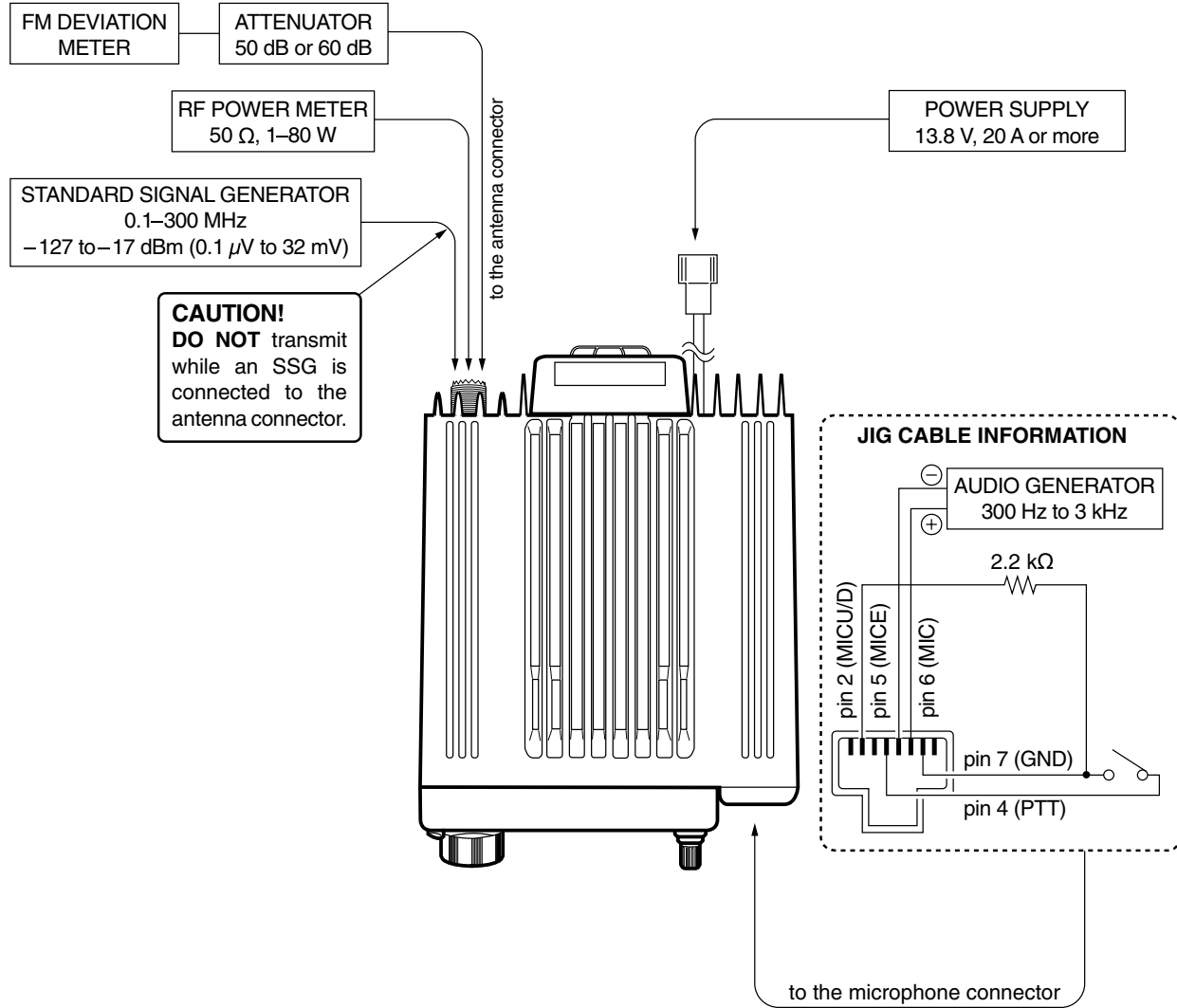

## ADJUSTMENT ITEM EXPLANATION

Starting item

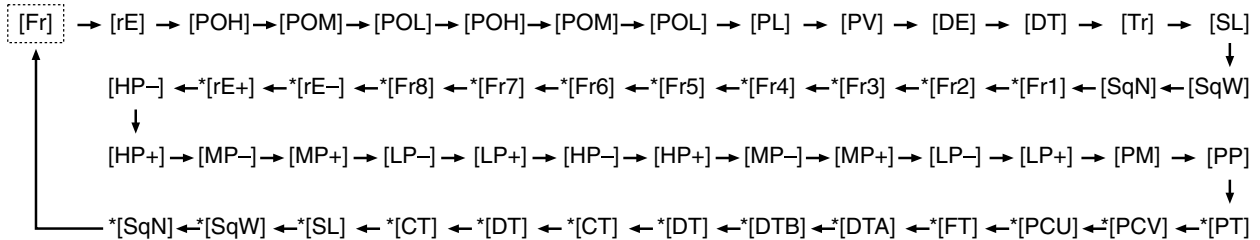

DISPLAY	ADJUSTMENT ITEMS	DISPLAY	ADJUSTMENT ITEMS
[Fr]	Reference frequency	*[rE-], *[rE+]	Reference voltage
[rF]	Reference voltage	[HP-], [HP+], [MP-], [MP+], [LP-], [LP+]	Temperature correction
[POH], [POM], [POL]	VHF/UHF output power	[PM]	Protect scale
[PL]	Transmit minimum voltage	[PP]	Protect power
[PV]	Protect voltage	*[PT]	Protect time
[DE]	Frequency deviation	*[PCV], *[PCU]	Protect temperature
[DT]	DTCS wave form	*[FT]	Cooling fan temperature
[Tr]	Tracking	*[DTA], *[DTB]	DTCS wave form
[SL]	S-Meter	*[DT], *[CT]	DTCS/CTCSS amplitude
[SqW]	Squelch level (Wide)	*[SL]	S-Meter
[SqN]	Squelch level (Narrow)	*[SqW]	Squelch level (Wide)
*[Fr1], *[Fr2], *[Fr3], *[Fr4], *[Fr5], *[Fr6], *[Fr7], *[Fr8]	Reference frequency's temperature correction	*[SqN]	Squelch level (Narrow)

\*Not adjust items

## 5-2 SOFTWARE ADJUSTMENTS (TRANSMITTING)

ADJUSTMENT	ADJUSTMENT CONDITION	OPERATION
REFERENCE FREQUENCY [Fr]	1 <ul style="list-style-type: none"> <li>Operating frequency : 445.0 MHz</li> <li>Loosely couple a frequency counter to the antenna connector on the rear panel.</li> <li>Transmitting</li> </ul>	<ul style="list-style-type: none"> <li>Turn the [DIAL] to set to 445.0000 MHz.</li> <li>Push the [BAND] key.</li> </ul>
REFERENCE VOLTAGE [rE]	1 <ul style="list-style-type: none"> <li>Operating frequency : 445.0 MHz</li> <li>Receiving</li> </ul>	<ul style="list-style-type: none"> <li>Push the [BAND] key.</li> </ul>
VHF OUTPUT POWER (High) [POH]	1 <ul style="list-style-type: none"> <li>Operating frequency : 146.0 MHz</li> <li>Connect an RF power meter to the antenna connector.</li> <li>Transmitting</li> </ul>	<ul style="list-style-type: none"> <li>Turn the [DIAL] to set the VHF high power to 55 W.</li> <li>Push the [BAND] key.</li> </ul>
(Middle) [POM]	2 <ul style="list-style-type: none"> <li>Transmitting</li> </ul>	<ul style="list-style-type: none"> <li>Turn the [DIAL] to set the VHF middle power to 15 W.</li> <li>Push the [BAND] key.</li> </ul>
(Low) [POL]	3 <ul style="list-style-type: none"> <li>Transmitting</li> </ul>	<ul style="list-style-type: none"> <li>Turn the [DIAL] to set the VHF low power to 5 W.</li> <li>Push the [BAND] key.</li> </ul>
UHF OUTPUT POWER (High) [POH]	1 <ul style="list-style-type: none"> <li>Operating frequency : 445.0 MHz</li> <li>Connect an RF power meter to the antenna connector.</li> <li>Transmitting</li> </ul>	<ul style="list-style-type: none"> <li>Turn the [DIAL] to set the UHF high power to 50 W.</li> <li>Push the [BAND] key.</li> </ul>
(Middle) [POM]	2 <ul style="list-style-type: none"> <li>Transmitting</li> </ul>	<ul style="list-style-type: none"> <li>Turn the [DIAL] to set the UHF middle power to 15 W.</li> <li>Push the [BAND] key.</li> </ul>
(Low) [POL]	3 <ul style="list-style-type: none"> <li>Transmitting</li> </ul>	<ul style="list-style-type: none"> <li>Turn the [DIAL] to set the UHF low power to 5 W.</li> <li>Push the [BAND] key.</li> </ul>
TRANSMIT MINIMUM VOLTAGE [PL]	1 <ul style="list-style-type: none"> <li>Operating frequency : 440.0 MHz</li> <li>Connect an RF power meter to the antenna connector.</li> <li>Transmitting</li> </ul>	<ul style="list-style-type: none"> <li>Turn the [DIAL] to set to 1 W.</li> <li>Push the [BAND] key.</li> </ul>
	2 <ul style="list-style-type: none"> <li>Operating frequency : 445.0 MHz</li> <li>Transmitting</li> </ul>	<ul style="list-style-type: none"> <li>Turn the [DIAL] to set to 1 W.</li> <li>Push the [BAND] key.</li> </ul>
	3 <ul style="list-style-type: none"> <li>Operating frequency : 450.0 MHz</li> <li>Transmitting</li> </ul>	<ul style="list-style-type: none"> <li>Turn the [DIAL] to set to 1 W.</li> <li>Push the [BAND] key.</li> </ul>
PROTECT VOLTAGE [PV]	1 <ul style="list-style-type: none"> <li>Operating frequency : 146.0 MHz</li> <li>[High]/[Middle]/[Low] switch : High</li> <li>Connect an RF power meter to the antenna connector.</li> <li>Transmitting</li> </ul>	<ul style="list-style-type: none"> <li>Push the [BAND] key.</li> </ul>
	2 <ul style="list-style-type: none"> <li>Operating frequency : 445.0 MHz</li> <li>Transmitting</li> </ul>	<ul style="list-style-type: none"> <li>Push the [BAND] key.</li> </ul>

## SOFTWARE ADJUSTMENTS (TRANSMITTING AND RECEIVING)–Continued

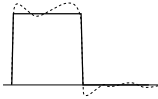
ADJUSTMENT	ADJUSTMENT CONDITION	OPERATION
FREQUENCY DEVIATION (VHF band) [DE]	1 <ul style="list-style-type: none"> <li>Operating frequency : 144.0 MHz</li> <li>Connect an audio generator to the [MIC] jack and set as : +20 dB</li> <li>Connect an FM deviation meter to the antenna connector and set as :               <ul style="list-style-type: none"> <li>HPF : 50 Hz</li> <li>LPF : 20 kHz</li> <li>De-emphasis : OFF</li> <li>Detector : (P–P)/2</li> </ul> </li> <li>Transmitting</li> </ul>	<ul style="list-style-type: none"> <li>Turn the [DIAL] to set to <math>\pm 4.6</math> kHz.</li> <li>Push the [BAND] key.</li> </ul>
	2 <ul style="list-style-type: none"> <li>Operating frequency : 148.0 MHz</li> <li>Transmitting</li> </ul>	<ul style="list-style-type: none"> <li>Turn the [DIAL] to set to <math>\pm 4.6</math> kHz.</li> <li>Push the [BAND] key.</li> </ul>
(UHF band) [DE]	3 <ul style="list-style-type: none"> <li>Operating frequency : 440.0 MHz</li> <li>Transmitting</li> </ul>	<ul style="list-style-type: none"> <li>Turn the [DIAL] to set to <math>\pm 4.6</math> kHz.</li> <li>Push the [BAND] key.</li> </ul>
	4 <ul style="list-style-type: none"> <li>Operating frequency : 450.0 MHz</li> <li>Transmitting</li> </ul>	<ul style="list-style-type: none"> <li>Turn the [DIAL] to set to <math>\pm 4.6</math> kHz.</li> <li>Push the [BAND] key.</li> </ul>
DTCS WAVE FORM (VHF band) [DE]	1 <ul style="list-style-type: none"> <li>Operating frequency : 146.0 MHz</li> <li>No audio signal is applied to the [MIC] jack.</li> <li>DTCS code : 007</li> <li>Set an FM deviation meter as:               <ul style="list-style-type: none"> <li>HPF : OFF</li> <li>LPF : 20 kHz</li> <li>De-emphasis : OFF</li> <li>Detector : (P–P)/2</li> </ul> </li> <li>Transmitting</li> </ul>	<ul style="list-style-type: none"> <li>Turn the [DIAL] to set to flat wave form as shown below.</li> <li>Push the [BAND] key.</li> </ul> <div style="text-align: center;"> <p>Set to flat wave form</p>  </div>
(UHF band) [DE]	2 <ul style="list-style-type: none"> <li>Operating frequency : 445.0 MHz</li> <li>Transmitting</li> </ul>	<ul style="list-style-type: none"> <li>Turn the [DIAL] to set to flat wave form as same as VHF band.</li> <li>Push the [BAND] key.</li> </ul>
TRACKING (Low band) [Tr]	1 <ul style="list-style-type: none"> <li>Operating frequency : 118.1 MHz</li> <li>Connect an SSG to the antenna connector and set as               <ul style="list-style-type: none"> <li>Level : 1 <math>\mu</math>V* (–107 dBm)</li> <li>Modulation : 1 kHz</li> <li>Deviation : <math>\pm 3.5</math> kHz</li> </ul> </li> <li>Receiving</li> </ul>	<ul style="list-style-type: none"> <li>Push the [BAND] key.</li> </ul>
	2 <ul style="list-style-type: none"> <li>Operating frequency : 146.1 MHz</li> <li>Receiving</li> </ul>	<ul style="list-style-type: none"> <li>Push the [BAND] key.</li> </ul>
	3 <ul style="list-style-type: none"> <li>Operating frequency : 160.1 MHz</li> <li>Receiving</li> </ul>	<ul style="list-style-type: none"> <li>Push the [BAND] key.</li> </ul>
	4 <ul style="list-style-type: none"> <li>Operating frequency : 173.9 MHz</li> <li>Receiving</li> </ul>	<ul style="list-style-type: none"> <li>Push the [BAND] key.</li> </ul>
(Middle1 band) [Tr]	5 <ul style="list-style-type: none"> <li>Operating frequency : 230.1 MHz</li> <li>Connect an SSG to the antenna connector and set as               <ul style="list-style-type: none"> <li>Level : 1 <math>\mu</math>V* (–107 dBm)</li> <li>Modulation : 1 kHz</li> <li>Deviation : <math>\pm 3.5</math> kHz</li> </ul> </li> <li>Receiving</li> </ul>	<ul style="list-style-type: none"> <li>Push the [BAND] key.</li> </ul>
	6 <ul style="list-style-type: none"> <li>Operating frequency : 260.1 MHz</li> <li>Receiving</li> </ul>	<ul style="list-style-type: none"> <li>Push the [BAND] key.</li> </ul>
	7 <ul style="list-style-type: none"> <li>Operating frequency : 380.1 MHz</li> <li>Receiving</li> </ul>	<ul style="list-style-type: none"> <li>Push the [BAND] key.</li> </ul>
	8 <ul style="list-style-type: none"> <li>Operating frequency : 399.9 MHz</li> <li>Receiving</li> </ul>	<ul style="list-style-type: none"> <li>Push the [BAND] key.</li> </ul>

\*This output level of a standard signal generator (SSG) is indicated as SSG's open circuit.

## SOFTWARE ADJUSTMENT (RECEIVING)–Continued

ADJUSTMENT	ADJUSTMENT CONDITION	OPERATION
TRACKING (Middle2 band) [Tr]	9 • Operating frequency : 400.1 MHz • Connect an SSG to the antenna connector and set as Level : 1 $\mu$ V* (–107 dBm) Modulation : 1 kHz Deviation : $\pm$ 3.5 kHz • Receiving	• Push the [BAND] key.
	10 • Operating frequency : 429.9 MHz • Receiving	• Push the [BAND] key.
	11 • Operating frequency : 480.1 MHz • Receiving	• Push the [BAND] key.
	12 • Operating frequency : 549.9 MHz • Receiving	• Push the [BAND] key.
(High band) [Tr]	13 • Operating frequency : 810.1 MHz • Connect an SSG to the antenna connector and set as Level : 1 $\mu$ V* (–107 dBm) Modulation : 1 kHz Deviation : $\pm$ 3.5 kHz • Receiving	• Push the [BAND] key.
	14 • Operating frequency : 905.1 MHz • Receiving	• Push the [BAND] key.
	15 • Operating frequency : 999.9 MHz • Receiving	• Push the [BAND] key.
S-METER [SL]	1 • Operating frequency : 146.1 MHz • Connect an SSG to the antenna connector and set as Level : 1 $\mu$ V* (–107 dBm) Modulation : 1 kHz Deviation : $\pm$ 3.5 kHz • Receiving	• Push the [BAND] key.
	2 • Operating frequency : 445.1 MHz • Receiving	• Push the [BAND] key.
	3 • Operating frequency : 435.9 MHz • Receiving	• Push the [BAND] key.
	4 • Operating frequency : 810.1 MHz • Set an SSG as Level : 5.6 $\mu$ V* (–92 dBm) Modulation : 1 kHz Deviation : $\pm$ 3.5 kHz • Receiving	• Push the [BAND] key.

\*This output level of a standard signal generator (SSG) is indicated as SSG's open circuit.

## SOFTWARE ADJUSTMENT (RECEIVING)–Continued

ADJUSTMENT	ADJUSTMENT CONDITION	OPERATION
SQUELCH LEVEL (Wide) [SqW]	1 • Operating frequency : 146.1 MHz • Connect an SSG to the antenna connector and set as Level : 0.079 $\mu$ V* (–129 dBm) Modulation : 1 kHz Deviation : $\pm$ 3.5 kHz • Receiving	• Push the [BAND] key.
	2 • Operating frequency : 445.1 MHz • Receiving	• Push the [BAND] key.
	3 • Operating frequency : 435.1 MHz • Set an SSG as: Level : 0.1 $\mu$ V* (–127 dBm) • Receiving	• Push the [BAND] key.
	4 • Operating frequency : 810.1 MHz • Set an SSG as: Level : 0.25 $\mu$ V* (–119 dBm) • Receiving	• Push the [BAND] key.
(Narrow) [SqN]	5 • Operating frequency : 146.1 MHz • Connect an SSG to the antenna connector and set as Level : 0.071 $\mu$ V* (–130 dBm) Modulation : 1 kHz Deviation : $\pm$ 3.5 kHz • Receiving	• Push the [BAND] key.
	6 • Operating frequency : 445.1 MHz • Receiving	• Push the [BAND] key.
	7 • Operating frequency : 435.1 MHz • Set an SSG as: Level : 0.1 $\mu$ V* (–127 dBm) • Receiving	• Push the [BAND] key.
	8 • Operating frequency : 810.1 MHz • Set an SSG as: Level : 0.25 $\mu$ V* (–119 dBm) • Receiving	• Push the [BAND] key.
TEMP. CORRECTION <High power> (VHF –10°C) [HP–]	1 • Operating frequency : 146.0 MHz • Receiving	• Turn the [DIAL] to set to “F9” on the display. • Push the [BAND] key.
(VHF +60°C) [HP–]	2 • Operating frequency : 146.0 MHz • Receiving	• Turn the [DIAL] to set to “F9” on the display. • Push the [BAND] key.
<Mid. power> (VHF –10°C) [MP–]	3 • Operating frequency : 146.0 MHz • Receiving	• Turn the [DIAL] to set to “F9” on the display. • Push the [BAND] key.
(VHF +60°C) [MP–]	4 • Operating frequency : 146.0 MHz • Receiving	• Turn the [DIAL] to set to “F9” on the display. • Push the [BAND] key.
<Low power> (VHF –10°C) [LP–]	5 • Operating frequency : 146.0 MHz • Receiving	• Turn the [DIAL] to set to “F9” on the display. • Push the [BAND] key.
(VHF +60°C) [LP–]	6 • Operating frequency : 146.0 MHz • Receiving	• Turn the [DIAL] to set to “F9” on the display. • Push the [BAND] key.

## SOFTWARE ADJUSTMENT (RECEIVING)–Continued

ADJUSTMENT	ADJUSTMENT CONDITION	OPERATION
TEMP. CORRECTION <High power> (UHF -10°C) [HP-]	1 • Operating frequency : 445.0 MHz • Receiving	• Turn the [DIAL] to set to “F9” on the display. • Push the [BAND] key.
(UHF +60°C) [HP-]	2 • Operating frequency : 445.0 MHz • Receiving	• Turn the [DIAL] to set to “07” on the display. • Push the [BAND] key.
<Mid. power> (UHF -10°C) [MP-]	3 • Operating frequency : 445.0 MHz • Receiving	• Turn the [DIAL] to set to “00” on the display. • Push the [BAND] key.
(UHF +60°C) [MP-]	4 • Operating frequency : 445.0 MHz • Receiving	• Turn the [DIAL] to set to “00” on the display. • Push the [BAND] key.
<Low power> (UHF -10°C) [LP-]	5 • Operating frequency : 445.0 MHz • Receiving	• Turn the [DIAL] to set to “00” on the display. • Push the [BAND] key.
(UHF +60°C) [LP-]	6 • Operating frequency : 445.0 MHz • Receiving	• Turn the [DIAL] to set to “00” on the display. • Push the [BAND] key.
PROTECT SCALE (VHF) [PM]	1 • Operating frequency : 146.0 MHz • Receiving	• Turn the [DIAL] to set to 130 % on the display. • Push the [BAND] key.
(UHF) [PM]	2 • Operating frequency : 445.0 MHz • Receiving	• Turn the [DIAL] to set to 140 % on the display. • Push the [BAND] key.
PROTECT POWER (VHF) [PP]	1 • Operating frequency : 146.0 MHz • Receiving	• Turn the [DIAL] to set to 5 W on the display. • Push the [BAND] key.
(UHF) [PP]	2 • Operating frequency : 445.0 MHz • Receiving	• Turn the [DIAL] to set to 5 W on the display. • Push the [BAND] key.

# SECTION 6 PARTS LIST

## [CONTROL UNIT]

REF NO.	ORDER NO.	DESCRIPTION		M.
IC2	1110005780	S.IC	S-80945CLMC-G7F-T2	B
IC5	1180000420	S.IC	TA78L05F (TE12R)	B
IC6	1140011370	S.IC	HD6433842RD36H (FX2633D)	B
Q1	1530002690	S.TRANSISTOR	2SC4116-GR (TE85R)	B
Q2	1590001650	S.TRANSISTOR	XP4601 (TX)	B
Q3	1510000690	S.TRANSISTOR	2SA1734 (TE12R)	B
Q6	1530002690	S.TRANSISTOR	2SC4116-GR (TE85R)	B
Q7	1530002690	S.TRANSISTOR	2SC4116-GR (TE85R)	B
D4	1790001000	S.ZENER	MA8062-L (TX)	B
D5	1790001170	S.ZENER	MA8068-M (TX)	B
X1	6060000610	S.CERAMIC	EFOS4914E3	B
R1	7210002920	VARIABLE	EVU-F2AF20B55 (560K)	T
R2	7030003440	S.RESISTOR	ERJ3GEYJ 102 V (1 kΩ)	B
R5	7210002920	VARIABLE	EVU-F2AF20B55 (560K)	T
R6	7030003440	S.RESISTOR	ERJ3GEYJ 102 V (1 kΩ)	B
R9	7030003640	S.RESISTOR	ERJ3GEYJ 473 V (47 kΩ)	B
R11	7030003640	S.RESISTOR	ERJ3GEYJ 473 V (47 kΩ)	B
R13	7030003520	S.RESISTOR	ERJ3GEYJ 472 V (4.7 kΩ)	B
R14	7030003640	S.RESISTOR	ERJ3GEYJ 473 V (47 kΩ)	B
R21	7030003440	S.RESISTOR	ERJ3GEYJ 102 V (1 kΩ)	B
R22	7030003760	S.RESISTOR	ERJ3GEYJ 474 V (470 kΩ)	B
R23	7030003560	S.RESISTOR	ERJ3GEYJ 103 V (100 kΩ)	B
R24	7030003520	S.RESISTOR	ERJ3GEYJ 472 V (4.7 kΩ)	B
R25	7030003560	S.RESISTOR	ERJ3GEYJ 103 V (100 kΩ)	B
R26	7030003520	S.RESISTOR	ERJ3GEYJ 472 V (4.7 kΩ)	B
R28	7030003520	S.RESISTOR	ERJ3GEYJ 472 V (4.7 kΩ)	B
R29	7030003560	S.RESISTOR	ERJ3GEYJ 103 V (100 kΩ)	B
R41	7030003800	S.RESISTOR	ERJ3GEYJ 105 V (1 MΩ)	B
R42	7030003520	S.RESISTOR	ERJ3GEYJ 472 V (4.7 kΩ)	B
R43	7030003520	S.RESISTOR	ERJ3GEYJ 472 V (4.7 kΩ)	B
R44	7030001120	S.RESISTOR	MCR50JZHJ 82 Ω (820)	B
R58	7030003680	S.RESISTOR	ERJ3GEYJ 104 V (100 kΩ)	B
R59	7030003680	S.RESISTOR	ERJ3GEYJ 104 V (100 kΩ)	B
R60	7030003680	S.RESISTOR	ERJ3GEYJ 104 V (100 kΩ)	B
R61	7030003580	S.RESISTOR	ERJ3GEYJ 153 V (15 kΩ)	B
R65	7030000360	S.RESISTOR	MCR10EZHZJ 680 Ω (681)	B
R74	7030000360	S.RESISTOR	MCR10EZHZJ 680 Ω (681)	B
R75	7030003560	S.RESISTOR	ERJ3GEYJ 103 V (10 kΩ)	B
R76	7030003640	S.RESISTOR	ERJ3GEYJ 473 V (47 kΩ)	B
R77	7030003570	S.RESISTOR	ERJ3GEYJ 123 V (12 kΩ)	B
R79	7030000380	S.RESISTOR	MCR10EZHZJ 1 kΩ	B
R80	7030000380	S.RESISTOR	MCR10EZHZJ 1 kΩ	B
R81	7030000360	S.RESISTOR	MCR10EZHZJ 680 Ω (681)	B
R82	7030000360	S.RESISTOR	MCR10EZHZJ 680 Ω (681)	B
R84	7030003520	S.RESISTOR	ERJ3GEYJ 472 V (4.7 kΩ)	B
C1	4030006880	S.CERAMIC	C1608 JB 1H 472K-T	B
C3	4030006880	S.CERAMIC	C1608 JB 1H 472K-T	B
C5	4030007130	S.CERAMIC	C1608 CH 1H 101J-T	B
C7	4030007130	S.CERAMIC	C1608 CH 1H 101J-T	B
C8	4030007130	S.CERAMIC	C1608 CH 1H 101J-T	B
C10	4030007130	S.CERAMIC	C1608 CH 1H 101J-T	B
C25	4030006860	S.CERAMIC	C1608 JB 1H 102K-T	B
C26	4030006900	S.CERAMIC	C1608 JB 1H 103K-T	B
C27	4030006860	S.CERAMIC	C1608 JB 1H 102K-T	B
C29	4030006860	S.CERAMIC	C1608 JB 1H 102K-T	B
C30	4030007090	S.CERAMIC	C1608 CH 1H 470J-T	B
C31	4030007090	S.CERAMIC	C1608 CH 1H 470J-T	B
C34	4030006900	S.CERAMIC	C1608 JB 1H 103K-T	B
C35	4030011600	S.CERAMIC	C1608 JB 1E 104K-T	B
C36	4030011600	S.CERAMIC	C1608 JB 1E 104K-T	B
C37	4030011600	S.CERAMIC	C1608 JB 1E 104K-T	B
C46	4510007310	S.ELECTROLYTIC	16 CV 10 BS	B
C49	4030006900	S.CERAMIC	C1608 JB 1H 103K-T	B
C50	4030006860	S.CERAMIC	C1608 JB 1H 102K-T	B
C51	4510007310	S.ELECTROLYTIC	16 CV 10 BS	B

M.=Mounted side (T: Mounted on the Top side, B: Mounted on the Bottom side)

## [CONTROL UNIT]

REF NO.	ORDER NO.	DESCRIPTION		M.
J3	6510023680	CONNECTOR	2633 FRONT CONNECTOR	B
DS1	5030002580	LCD	L2-0736TAY	T
DS13	5040002930	S.LED	SML-512MW T86P	T
DS14	5040002930	S.LED	SML-512MW T86P	T
DS15	5040002930	S.LED	SML-512MW T86P	T
DS16	5040002930	S.LED	SML-512MW T86P	T
DS17	5040002930	S.LED	SML-512MW T86P	T
DS18	5040002930	S.LED	SML-512MW T86P	T
DS20	5040002930	S.LED	SML-512MW T86P	T
DS21	5040002910	S.LED	SML-020MYT	T
DS22	5040002920	LED	CV1074	T
DS23	5040002930	S.LED	SML-512MW T86P	B
S1	2240000150	SWITCH	JRS0000-1401	T
S3	2260001890	S.SWITCH	SKQDPA	T
S4	2260001890	S.SWITCH	SKQDPA	T
S5	2260001890	S.SWITCH	SKQDPA	T
S6	2260001890	S.SWITCH	SKQDPA	T
S7	2260001890	S.SWITCH	SKQDPA	T
S8	2260001890	S.SWITCH	SKQDPA	T
S9	2260001890	S.SWITCH	SKQDPA	T
S10	2260001890	S.SWITCH	SKQDPA	T
S11	2260001890	S.SWITCH	SKQDPA	T
W1	7030000010	S.JUMPER	MCR10EZHZJ JPW (000)	B
EP9	6910015120	S.BEAD	MMZ2012D 301BT	B
EP10	6910012350	S.BEAD	MMZ1608Y 102BT	B
EP11	6910012350	S.BEAD	MMZ1608Y 102BT	B
EP12	6910015120	S.BEAD	MMZ2012D 301BT	B
EP17	6910015120	S.BEAD	MMZ2012D 301BT	B
EP18	8930060040	LCD CONTACT	SRCN-2633-SP-N-W	T
EP19	0910056472	PCB	B 5945B	T

## [VCO UNIT]

REF NO.	ORDER NO.	DESCRIPTION		M.
Q1	1590003290	S.TRANSISTOR	UN9213J-(TX)	B
Q2	1590003300	S.TRANSISTOR	UN921NJ-(TX)	T
Q3	1530003580	S.TRANSISTOR	2SC5231C8-TL	T
Q4	1530003580	S.TRANSISTOR	2SC5231C8-TL	T
Q5	1530003580	S.TRANSISTOR	2SC5231C8-TL	T
Q50	1530002560	S.TRANSISTOR	2SC4403-3-TL	T
Q100	1590003290	S.TRANSISTOR	UN9213J-(TX)	T
Q101	1530003580	S.TRANSISTOR	2SC5231C8-TL	T
Q102	1530003580	S.TRANSISTOR	2SC5231C8-TL	T
Q103	1530003580	S.TRANSISTOR	2SC5231C8-TL	T
Q104	1530003580	S.TRANSISTOR	2SC5231C8-TL	T
Q105	1590003290	S.TRANSISTOR	UN9213J-(TX)	T
D1	1720000650	S.VARICAP	1SV286 (TPH3)	T
D2	1720000730	S.VARICAP	MA2S30400L	T
D3	1720000730	S.VARICAP	MA2S30400L	T
D4	1790001260	S.DIODE	MA2S077-(TX)	T
D5	1790001620	S.DIODE	1SV308 (TPL3)	T
D6	1790001260	S.DIODE	MA2S077-(TX)	T
D50	1790001260	S.DIODE	MA2S077-(TX)	T
D51	1790001260	S.DIODE	MA2S077-(TX)	T
D100	1720000650	S.VARICAP	1SV286 (TPH3)	T
D101	1750000720	S.VARICAP	HVC375BTRF	T
D102	1750000720	S.VARICAP	HVC375BTRF	T
D103	1790001620	S.DIODE	1SV308 (TPL3)	T
D104	1790001260	S.DIODE	MA2S077-(TX)	T
D105	1790001260	S.DIODE	MA2S077-(TX)	T

S.=Surface mount

**[VCO UNIT]**

REF NO.	ORDER NO.	DESCRIPTION	M.
D106	1790001620	S.DIODE 1SV308 (TPL3)	T
D107	1790001260	S.DIODE MA2S077-(TX)	B
L1	6200001980	S.COIL NL 252018T-1R0J	T
L2	62000010100	S.COIL C2012C-33NG	T
L3	62000010210	S.COIL C2012C-22NG	T
L4	6200006980	S.COIL ELJRE R10G-F	T
L5	6200003540	S.COIL MLF1608D R22K-T	T
L6	6200006990	S.COIL ELJRE 56NG-F	T
L7	6200007610	S.COIL LL1608-FH39NJ	T
L8	6200007610	S.COIL LL1608-FH39NJ	T
L50	6200006990	S.COIL ELJRE 56NG-F	T
L51	6200005690	S.COIL ELJRE 18NG-F	T
L100	6200002610	S.COIL NL 252018T-R47J	T
L101	6200002330	S.COIL LQW31HN15NJ01L	T
L102	6200005730	S.COIL ELJRE 39NG-F	T
L103	6200005700	S.COIL ELJRE 22NG-F	T
L104	6200005690	S.COIL ELJRE 18NG-F	T
L105	6200005700	S.COIL ELJRE 22NG-F	T
L106	6200005660	S.COIL ELJRE 10NG-F	T
L107	6200005660	S.COIL ELJRE 10NG-F	T
L108	6200005670	S.COIL ELJRE 12NG-F	T
L109	6200005670	S.COIL ELJRE 12NG-F	T
L110	6200005660	S.COIL ELJRE 10NG-F	T
R1	7030003560	S.RESISTOR ERJ3GEYJ 103 V (10 kΩ)	B
R2	7030003600	S.RESISTOR ERJ3GEYJ 223 V (22 kΩ)	T
R3	7030003440	S.RESISTOR ERJ3GEYJ 102 V (1 kΩ)	T
R4	7030003680	S.RESISTOR ERJ3GEYJ 104 V (100 kΩ)	T
R5	7030003840	S.RESISTOR ERJ3GEYJ 225 V (2.2 MΩ)	T
R6	7030003640	S.RESISTOR ERJ3GEYJ 473 V (47 kΩ)	T
R7	7030003440	S.RESISTOR ERJ3GEYJ 102 V (1 kΩ)	T
R8	7030003520	S.RESISTOR ERJ3GEYJ 472 V (4.7 kΩ)	T
R9	7030003560	S.RESISTOR ERJ3GEYJ 103 V (10 kΩ)	T
R10	7030003560	S.RESISTOR ERJ3GEYJ 103 V (10 kΩ)	T
R11	7030003280	S.RESISTOR ERJ3GEYJ 470 V (47 Ω)	T
R12	7030003430	S.RESISTOR ERJ3GEYJ 821 V (820 Ω)	T
R13	7030003330	S.RESISTOR ERJ3GEYJ 121 V (120 Ω)	T
R14	7030003560	S.RESISTOR ERJ3GEYJ 103 V (10 kΩ)	T
R15	7030003470	S.RESISTOR ERJ3GEYJ 182 V (1.8 kΩ)	T
R16	7030003440	S.RESISTOR ERJ3GEYJ 102 V (1 kΩ)	T
R17	7030003320	S.RESISTOR ERJ3GEYJ 101 V (100 Ω)	T
R18	7030003520	S.RESISTOR ERJ3GEYJ 821 V (820 Ω)	T
R19	7030003560	S.RESISTOR ERJ3GEYJ 103 V (10 kΩ)	T
R20	7030003470	S.RESISTOR ERJ3GEYJ 182 V (1.8 kΩ)	T
R21	7030003400	S.RESISTOR ERJ3GEYJ 471 V (470 Ω)	T
R22	7030004050	S.RESISTOR ERJ3GEYJ 1R0 V (1 Ω)	T
R23	7030003480	S.RESISTOR ERJ3GEYJ 222 V (2.2 kΩ)	T
R24	7030004050	S.RESISTOR ERJ3GEYJ 1R0 V (1 Ω)	T
R25	7030004050	S.RESISTOR ERJ3GEYJ 1R0 V (1 Ω)	T
R26	7030003440	S.RESISTOR ERJ3GEYJ 102 V (1 kΩ)	T
R50	7030003240	S.RESISTOR ERJ3GEYJ 220 V (22 Ω)	T
R51	7030003520	S.RESISTOR ERJ3GEYJ 472 V (4.7 kΩ)	T
R52	7030003600	S.RESISTOR ERJ3GEYJ 223 V (22 kΩ)	T
R53	7030003560	S.RESISTOR ERJ3GEYJ 103 V (10 kΩ)	T
R54	7030003480	S.RESISTOR ERJ3GEYJ 222 V (2.2 kΩ)	T
R55	7030003840	S.RESISTOR ERJ3GEYJ 225 V (2.2 MΩ)	T
R100	7030003600	S.RESISTOR ERJ3GEYJ 223 V (22 kΩ)	T
R101	7030003550	S.RESISTOR ERJ3GEYJ 822 V (8.2 kΩ)	T
R102	7030003840	S.RESISTOR ERJ3GEYJ 225 V (2.2 MΩ)	T
R103	7030003680	S.RESISTOR ERJ3GEYJ 104 V (100 kΩ)	T
R104	7030003560	S.RESISTOR ERJ3GEYJ 103 V (10 kΩ)	T
R105	7030003560	S.RESISTOR ERJ3GEYJ 103 V (10 kΩ)	T
R106	7030003280	S.RESISTOR ERJ3GEYJ 470 V (47 Ω)	T
R107	7030003370	S.RESISTOR ERJ3GEYJ 271 V (270 Ω)	T
R108	7030003560	S.RESISTOR ERJ3GEYJ 103 V (10 kΩ)	T
R109	7030003470	S.RESISTOR ERJ3GEYJ 182 V (1.8 kΩ)	T
R110	7030003320	S.RESISTOR ERJ3GEYJ 101 V (100 Ω)	T
R111	7030003520	S.RESISTOR ERJ3GEYJ 472 V (4.7 kΩ)	T
R112	7030003560	S.RESISTOR ERJ3GEYJ 103 V (10 kΩ)	T
R113	7030003470	S.RESISTOR ERJ3GEYJ 182 V (1.8 kΩ)	T
R114	7030003320	S.RESISTOR ERJ3GEYJ 101 V (100 Ω)	T
R115	7030004050	S.RESISTOR ERJ3GEYJ 1R0 V (1 Ω)	T
R116	7030003520	S.RESISTOR ERJ3GEYJ 472 V (4.7 kΩ)	T
R117	7030003210	S.RESISTOR ERJ3GEYJ 120 V (12 Ω)	T
R118	7030003520	S.RESISTOR ERJ3GEYJ 472 V (4.7 kΩ)	T
R119	7030003210	S.RESISTOR ERJ3GEYJ 120 V (12 Ω)	T
R120	7030003320	S.RESISTOR ERJ3GEYJ 101 V (100 Ω)	T
R121	7030003440	S.RESISTOR ERJ3GEYJ 102 V (1 kΩ)	T

M.=Mounted side (T: Mounted on the Top side, B: Mounted on the Bottom side)

**[VCO UNIT]**

REF NO.	ORDER NO.	DESCRIPTION	M.
R122	7030003320	S.RESISTOR ERJ3GEYJ 390 V (39 Ω)	T
R123	7030003730	S.RESISTOR ERJ3GEYJ 274 V (270 kΩ)	T
R124	7030003520	S.RESISTOR ERJ3GEYJ 472 V (4.7 kΩ)	T
R125	7030003280	S.RESISTOR ERJ3GEYJ 470 V (47 Ω) [USA] only	T
	7030003520	S.RESISTOR ERJ3GEYJ 472 V (4.7 kΩ) except [USA]	T
R126	7030003520	S.RESISTOR ERJ3GEYJ 472 V (4.7 kΩ)	T
R127	7030003240	S.RESISTOR ERJ3GEYJ 220 V (22 Ω) [USA] only	T
R128	7030003240	S.RESISTOR ERJ3GEYJ 220 V (22 Ω) [USA] only	B
C1	4030007090	S.CERAMIC C1608 CH 1H 470J-T	T
C2	4030007090	S.CERAMIC C1608 CH 1H 470J-T	T
C3	4030007090	S.CERAMIC C1608 CH 1H 470J-T	T
C4	4030007090	S.CERAMIC C1608 CH 1H 470J-T	T
C5	4030007090	S.CERAMIC C1608 CH 1H 470J-T	B
C6	4030007090	S.CERAMIC C1608 CH 1H 470J-T	T
C7	4030007090	S.CERAMIC C1608 CH 1H 470J-T	T
C8	4030007090	S.CERAMIC C1608 CH 1H 470J-T	B
C9	4030011600	S.CERAMIC C1608 JB 1E 104K-T	T
C10	4030006860	S.CERAMIC C1608 CH 1H 102K-T	T
C11	4030006860	S.CERAMIC C1608 JB 1H 102K-T	B
C12	4030009500	S.CERAMIC C1608 CH 1H 0R5B-T	T
C13	4030006860	S.CERAMIC C1608 JB 1H 102K-T	T
C14	4030006860	S.CERAMIC C1608 JB 1H 102K-T	T
C15	4030006860	S.CERAMIC C1608 JB 1H 102K-T	T
C16	4030007020	S.CERAMIC C1608 CH 1H 120J-T	T
C17	4030006860	S.CERAMIC C1608 JB 1H 102K-T	T
C18	4030007050	S.CERAMIC C1608 CH 1H 220J-T	T
C19	4030007040	S.CERAMIC C1608 CH 1H 180J-T	T
C20	4030006920	S.CERAMIC C1608 CH 1H 010C-T	T
C21	4030006860	S.CERAMIC C1608 JB 1H 102K-T	T
C22	4030006920	S.CERAMIC C1608 CH 1H 010C-T	T
C23	4030007050	S.CERAMIC C1608 CH 1H 220J-T	T
C24	4030006860	S.CERAMIC C1608 JB 1H 102K-T	T
C25	4030006860	S.CERAMIC C1608 JB 1H 102K-T	T
C26	4030006910	S.CERAMIC C1608 CH 1H 0R5C-T	T
C27	4030006950	S.CERAMIC C1608 CH 1H 040C-T	T
C28	4030006990	S.CERAMIC C1608 CH 1H 080D-T	T
C29	4030007090	S.CERAMIC C1608 CH 1H 470J-T	T
C30	4030006860	S.CERAMIC C1608 JB 1H 102K-T	T
C31	4030006920	S.CERAMIC C1608 CH 1H 010C-T	T
C32	4030007040	S.CERAMIC C1608 CH 1H 180J-T	T
C33	4030007040	S.CERAMIC C1608 CH 1H 180J-T	T
C34	4030006860	S.CERAMIC C1608 JB 1H 102K-T	T
C36	4030007030	S.CERAMIC C1608 CH 1H 150J-T	T
C37	4030007060	S.CERAMIC C1608 CH 1H 270J-T	T
C38	4030007030	S.CERAMIC C1608 CH 1H 150J-T	T
C39	4030006860	S.CERAMIC C1608 JB 1H 102K-T	T
C40	4030006860	S.CERAMIC C1608 JB 1H 102K-T	T
C50	4030006860	S.CERAMIC C1608 JB 1H 102K-T	T
C51	4030006900	S.CERAMIC C1608 JB 1H 103K-T	T
C52	4030009530	S.CERAMIC C1608 CH 1H 030B-T	T
C53	4030006950	S.CERAMIC C1608 CH 1H 040C-T	T
C54	4030007090	S.CERAMIC C1608 CH 1H 470J-T	T
C55	4030006940	S.CERAMIC C1608 CH 1H 030C-T	T
C56	4030006940	S.CERAMIC C1608 CH 1H 030C-T	T
C100	4030011600	S.CERAMIC C1608 JB 1E 104K-T	T
C101	4030006860	S.CERAMIC C1608 JB 1H 102K-T	T
C102	4030006860	S.CERAMIC C1608 JB 1H 102K-T	T
C103	4030009570	S.CERAMIC C1608 CH 1H 0R3B-T	T
C104	4030006860	S.CERAMIC C1608 JB 1H 102K-T	T
C105	4030007090	S.CERAMIC C1608 CH 1H 470J-T	T
C106	4030006950	S.CERAMIC C1608 CH 1H 040C-T	T
C107	4030007090	S.CERAMIC C1608 CH 1H 470J-T	T
C108	4030007020	S.CERAMIC C1608 CH 1H 120J-T	T
C109	4030007020	S.CERAMIC C1608 CH 1H 120J-T	T
C110	4030006910	S.CERAMIC C1608 CH 1H 0R5C-T	T
C111	4030007090	S.CERAMIC C1608 CH 1H 470J-T	T
C112	4030006860	S.CERAMIC C1608 JB 1H 102K-T	T
C113	4030006940	S.CERAMIC C1608 CH 1H 030C-T	T
C114	4030006950	S.CERAMIC C1608 CH 1H 040C-T	T
C115	4030006860	S.CERAMIC C1608 JB 1H 102K-T	T
C116	4030006860	S.CERAMIC C1608 JB 1H 102K-T	T
C117	4030006950	S.CERAMIC C1608 CH 1H 040C-T	T
C118	4030006940	S.CERAMIC C1608 CH 1H 030C-T	T
C119	4030006990	S.CERAMIC C1608 CH 1H 080D-T	T
C120	4030006860	S.CERAMIC C1608 JB 1H 102K-T	T
C121	4030006920	S.CERAMIC C1608 CH 1H 010C-T	T
C122	4030006980	S.CERAMIC C1608 CH 1H 070D-T	T
C123	4030009520	S.CERAMIC C1608 CH 1H 020B-T	T

S.=Surface mount

[VCO UNIT]

REF NO.	ORDER NO.	DESCRIPTION		M.
C124	4030006980	S.CERAMIC	C1608 CH 1H 070D-T	T
C125	4030006860	S.CERAMIC	C1608 JB 1H 102K-T	T
C126	4030006950	S.CERAMIC	C1608 CH 1H 040C-T	T
C127	4030009520	S.CERAMIC	C1608 CH 1H 020B-T	T
C128	4030007130	S.CERAMIC	C1608 CH 1H 101J-T	T
C129	4030009510	S.CERAMIC	C1608 CH 1H 010B-T	T
C130	4030006860	S.CERAMIC	C1608 JB 1H 102K-T	T
C131	4030006860	S.CERAMIC	C1608 JB 1H 102K-T	B
C132	4030009540	S.CERAMIC	C1608 CH 1H 1R5B-T	T
C133	4030006950	S.CERAMIC	C1608 CH 1H 040C-T	T
C134	4030006860	S.CERAMIC	C1608 JB 1H 102K-T	T
C135	4030006950	S.CERAMIC	C1608 CH 1H 040C-T	T
C136	4550000540	S.TANTALUM	TESVA 1V 154M1-8L	B
C137	4550000530	S.TANTALUM	TESVA 1V 104M1-8L	B
C138	4030006930	S.CERAMIC	C1608 CH 1H 020C-T	B
J1	6910006810	CONNECTOR	IMSA-9210B-1-10Z204-T	B
J2	6910006810	CONNECTOR	IMSA-9210B-1-10Z204-T	B
W1	7030003860	S.JUMPER	ERJ3GE JPW V	except [USA] T
W2	7030003860	S.JUMPER	ERJ3GE JPW V	except [USA] B
EP1	0910056492	PCB	B 5947B	

[MAIN UNIT]

REF NO.	ORDER NO.	DESCRIPTION		M.
IC1	1140005990	S.IC	MB15A02PFV1-G-BND-ER	T
IC2	1140005990	S.IC	MB15A02PFV1-G-BND-ER	T
IC3	1110005340	S.IC	NJM12902V-TE1	B
IC4	1190000350	S.IC	M62363FP-650C	B
IC5	1130006220	S.IC	TC4W53FU (TE12L)	B
IC6	1130004200	S.IC	TC4S66F (TE85R)	T
IC7	1130004200	S.IC	TC4S66F (TE85R)	T
IC8	1110003200	S.IC	TA31136FN (EL)	B
IC9	1130006220	S.IC	TC4W53FU (TE12L)	T
IC10	1130006220	S.IC	TC4W53FU (TE12L)	T
IC11	1110004310	S.IC	M62352GP 75EC	T
IC12	1110005230	S.IC	μPC2757TB-E3	T
IC13	1150002160	IC	S-AV32 (I2)	B
IC14	1150002120	IC	S-AU82L (I)	B
IC15	1110004050	S.IC	NJM3404AV-TE1	B
IC501	1140009240	S.IC	HN58X24128FPI	T
IC502	1110005780	S.IC	S-80945CLMC-G7F-T2	B
IC503	1180001070	S.IC	TA7805F (TE16L)	B
IC504	1180001250	S.IC	TA7808F (TE16L)	B
IC505	1140011350	S.IC	HD6432143SA69FA (FX-2633B)	T
			except [USA]	
	1140011360	S.IC	HD6432143SA70FA (FX2633C)	T
			[USA] only	
IC506	1130007370	S.IC	TA75S558F (TE85L)	T
IC507	1110002750	S.IC	TA75S01F (TE85R)	B
IC508	1110004490	S.IC	M62429FP 700C	T
IC509	1130008090	S.IC	BU4066BCFV-E1	T
IC510	1110003090	IC	LA4425A	T
IC511	1110004050	S.IC	NJM3404AV-TE1	T
Q1	1590003290	S.TRANSISTOR	UN9213J-(TX)	B
Q2	1530002850	S.TRANSISTOR	2SC4116-BL (TE85R)	T
Q3	1590001650	S.TRANSISTOR	XP4601 (TX)	T
Q4	1530002850	S.TRANSISTOR	2SC4116-BL (TE85R)	T
Q5	1590001190	S.TRANSISTOR	XP6501-(TX) .AB	T
Q6	1590002270	S.TRANSISTOR	UMG9N TL	T
Q7	1530002380	S.TRANSISTOR	2SC4215-Y (TE85R)	B
Q8	1590002380	S.TRANSISTOR	XP1115 (TX)	T
Q9	1510000770	S.TRANSISTOR	2SA1586-GR (TE85R)	T
Q10	1530002690	S.TRANSISTOR	2SC4116-GR (TE85R)	T
Q11	1510000770	S.TRANSISTOR	2SA1586-GR (TE85R)	T
Q12	1530002690	S.TRANSISTOR	2SC4116-GR (TE85R)	T
Q13	1590001190	S.TRANSISTOR	XP6501-(TX) .AB	B
Q14	1590001450	S.FET	2SJ144-GR (TE85R)	T

M.=Mounted side (T: Mounted on the Top side, B: Mounted on the Bottom side)

[MAIN UNIT]

REF NO.	ORDER NO.	DESCRIPTION		M.
Q15	1530002850	S.TRANSISTOR	2SC4116-BL (TE85R)	B
Q16	1590001190	S.TRANSISTOR	XP6501-(TX) .AB	B
Q17	1530002850	S.TRANSISTOR	2SC4116-BL (TE85R)	B
Q18	1530002920	S.TRANSISTOR	2SC4226-T1 R25	B
Q19	1590003290	S.TRANSISTOR	UN9213J-(TX)	T
Q20	1590003290	S.TRANSISTOR	UN9213J-(TX)	B
Q21	1590003290	S.TRANSISTOR	UN9213J-(TX)	T
Q22	1510000580	S.TRANSISTOR	2SA1362-GR (TE85R)	T
Q23	1510000580	S.TRANSISTOR	2SA1362-GR (TE85R)	B
Q24	1590003240	S.TRANSISTOR	UN9114J-(TX)	B
Q25	1590003260	S.TRANSISTOR	UN9111N-(TX)	B
Q26	1590003240	S.TRANSISTOR	UN9114J-(TX)	B
Q27	1590003240	S.TRANSISTOR	UN9114J-(TX)	B
Q28	1590003240	S.TRANSISTOR	UN9114J-(TX)	B
Q29	1590003240	S.TRANSISTOR	UN9114J-(TX)	B
Q30	1530002680	S.TRANSISTOR	2SC3357-T1	B
Q31	1530003230	S.TRANSISTOR	2SC5085-Y (TE85R)	T
Q32	1580000760	S.FET	3SK299-T1 U73	T
Q33	1530002340	S.TRANSISTOR	2SC2954-T1	B
Q34	1530002680	S.TRANSISTOR	2SC3357-T1	T
Q35	1580000760	S.FET	3SK299-T1 U73	B
Q36	1530003260	S.TRANSISTOR	2SC5006-T1	T
Q37	1530003810	S.TRANSISTOR	2SC5008-T1	T
Q38	1580000760	S.FET	3SK299-T1 U73	T
Q39	1580000760	S.FET	3SK299-T1 U73	T
Q40	1530003810	S.TRANSISTOR	2SC5008-T1	T
Q41	1530003780	S.TRANSISTOR	2SC5624VH-TL	T
Q42	1590003230	S.TRANSISTOR	UN9113J-(TX)	T
Q43	1590003250	S.TRANSISTOR	UN9115J-(TX)	T
Q44	1530002060	S.TRANSISTOR	2SC4081 T106 R	T
Q45	1590003230	S.TRANSISTOR	UN9113J-(TX)	T
Q501	1520000270	S.TRANSISTOR	2SB1182 TL Q	T
Q502	1590003290	S.TRANSISTOR	UN9213J-(TX)	T
Q503	1510000670	S.TRANSISTOR	2SA1588-GR (TE85R)	T
Q504	1590001650	S.TRANSISTOR	XP4601 (TX)	B
Q505	1530002690	S.TRANSISTOR	2SC4116-GR (TE85R)	T
Q506	1530002850	S.TRANSISTOR	2SC4116-BL (TE85R)	T
Q507	1590003230	S.TRANSISTOR	UN9113J-(TX)	T
Q508	1590003290	S.TRANSISTOR	UN9213J-(TX)	T
Q509	1590003290	S.TRANSISTOR	UN9213J-(TX)	T
Q510	1590003270	S.TRANSISTOR	UN9210J-(TX)	T
Q511	1590003290	S.TRANSISTOR	UN9213J-(TX)	T
Q512	1530003090	S.TRANSISTOR	2SC4213-B (TE85R)	T
Q513	1590003230	S.TRANSISTOR	UN9113J-(TX)	B
Q514	1590003290	S.TRANSISTOR	UN9213J-(TX)	B
Q515	1590003240	S.TRANSISTOR	UN9114J-(TX)	B
Q516	1590003290	S.TRANSISTOR	UN9213J-(TX)	B
D1	1750000770	S.VARICAP	HVC376BTRF	T
D2	1750000940	S.DIODE	ISS400 TE61	T
D3	1750000940	S.DIODE	ISS400 TE61	T
D4	1750000370	S.DIODE	DA221 TL	T
D5	1750000370	S.DIODE	DA221 TL	T
D6	1750000370	S.DIODE	DA221 TL	B
D7	1750000520	S.DIODE	DAN222TL	T
D8	1750000800	S.DIODE	HVC136TRF	T
D9	1750000800	S.DIODE	HVC136TRF	B
D10	1750000800	S.DIODE	HVC136TRF	T
D12	1750000520	S.DIODE	DAN222TL	T
D13	1750000550	S.DIODE	1SS355 TE-17	B
D14	1750000550	S.DIODE	1SS355 TE-17	T
D15	1750000800	S.DIODE	HVC136TRF	B
D16	1750000800	S.DIODE	HVC136TRF	T
D17	1750000800	S.DIODE	HVC136TRF	T
D18	1750000800	S.DIODE	HVC136TRF	T
D19	1790001240	S.DIODE	MA2S728-(TX)	T
D20	1790001240	S.DIODE	MA2S728-(TX)	T
D21	1790001240	S.DIODE	MA2S728-(TX)	T
D22	1750000710	S.VARICAP	HVC350BTRF	T
D23	1750000710	S.VARICAP	HVC350BTRF	T
D24	1790001260	S.DIODE	MA2S077-(TX)	T
D25	1750000610	S.VARICAP	MA2SV0500L	T
D26	1720000700	S.VARICAP	1SV305 (TPL3)	T
D27	1790000980	S.DIODE	MA742 (TX)	B
D28	1790000980	S.DIODE	MA742 (TX)	T
D29	1750000710	S.VARICAP	HVC350BTRF	T
D30	1750000610	S.VARICAP	MA2SV0500L	T
D31	1720000700	S.VARICAP	1SV305 (TPL3)	T
D32	1790001260	S.DIODE	MA2S077-(TX)	T
D33	1790000980	S.DIODE	MA742 (TX)	B

S.=Surface mount

[MAIN UNIT]

REF NO.	ORDER NO.	DESCRIPTION		M.
D34	1790000980	S.DIODE	MA742 (TX)	B
D36	1750000610	S.VARICAP	MA2SV0500L	T
D37	1720000700	S.VARICAP	1SV305 (TPL3)	T
D38	1790001260	S.DIODE	MA2S077-(TX)	T
D39	1790001160	S.DIODE	1SS362 (TE85R)	T
D40	1750000510	S.DIODE	UM9401F	T
D41	1750000720	S.VARICAP	HVC375BTRF	T
D42	1790001620	S.DIODE	1SV308 (TPL3)	T
D43	1790001620	S.DIODE	1SV308 (TPL3)	T
D44	1790001620	S.DIODE	1SV308 (TPL3)	T
D45	1750000510	S.DIODE	UM9401F	T
D46	1750000940	S.DIODE	ISS400 TE61	T
D47	1750000940	S.DIODE	ISS400 TE61	T
D48	1710000870	S.DIODE	HVU131TRF	T
D49	1710000870	S.DIODE	HVU131TRF	T
D50	1750000510	S.DIODE	UM9401F	T
D51	1750000510	S.DIODE	UM9401F	B
D501	1730000520	ZENER	RD20E B2	T
D502	1790000700	DIODE	DSA3A1	T
D503	1790001260	S.DIODE	MA2S077-(TX)	B
D504	1750000940	S.DIODE	ISS400 TE61	T
D505	1750000940	S.DIODE	ISS400 TE61	T
D506	1730002340	S.ZENER	MA8047-M (TX)	B
D507	1750000940	S.DIODE	ISS400 TE61 [TPE], [EXP] only	T
D508	1750000940	S.DIODE	ISS400 TE61 [TPE], [KOR], [AUS] only	T
D510	1750000940	S.DIODE	ISS400 TE61 [TPE], [KOR] only	T
D511	1750000940	S.DIODE	ISS400 TE61 [TPE], [KOR] only	T
D512	1750000940	S.DIODE	ISS400 TE61 [TPE], [KOR] only	T
D513	1750000940	S.DIODE	ISS400 TE61 [TPE], [KOR] only	T
D514	1750000940	S.DIODE	ISS400 TE61 [TPE], [KOR] only	T
D516	1750000940	S.DIODE	ISS400 TE61 [TPE], [KOR] only	T
D517	1750000940	S.DIODE	ISS400 TE61 [TPE], [KOR] only	T
D518	1750000940	S.DIODE	ISS400 TE61 [TPE], [KOR] only	T
D519	1750000940	S.DIODE	ISS400 TE61 [TPE], [KOR] only	T
D521	1750000940	S.DIODE	ISS400 TE61 except [EXP]	T
D522	1750000940	S.DIODE	ISS400 TE61 except [EXP]	T
D523	1790000980	S.DIODE	MA742 (TX)	T
D524	1750000370	S.DIODE	DA221 TL	T
D525	1750000940	S.DIODE	ISS400 TE61	B
D526	1750000940	S.DIODE	ISS400 TE61	T
D527	1750000940	S.DIODE	ISS400 TE61	T
D528	1750000800	S.DIODE	HVC136TRF	T
D529	1750000800	S.DIODE	HVC136TRF	B
D530	1750000800	S.DIODE	HVC136TRF	B
D531	1750000520	S.DIODE	DAN222TL	T
FI1	2020001460	CERAMIC	CFWLA450KHFA-B0 (CFWS450HT)	T
FI2	2020001270	CERAMIC	CFWLB450KE2A-B0 (CFWM450E)	T
FI3	2010002560	S.MONOLITH	FL-344 (46.05 MHz)	T
FI4	2040001000	S.SAW	EFCH435MWNPN1 except [USA]	T
	2040001020	S.SAW	EFCH445MWNPN1 [USA] only	T
X1	6050011650	S.XTAL	CR-719 (15.2 MHz)	T
X2	6070000200	DISCRIMINATOR	CDBLA450KCAY24-B0	T
X501	6050009520	S.XTAL	CR-520 (19.6608 MHz+)	T
L1	6200007620	S.COIL	LL1608-FH47NJ	T
L2	6200004480	S.COIL	MLF1608D R82K-T	B
L3	6200010450	S.COIL	C2520C-R82G (0.82U)	B
L4	6200005690	S.COIL	ELJRE 18NG-F	B
L5	6200006670	S.COIL	ELJRE 68NG-F	B
L6	6200005720	S.COIL	ELJRE 33NG-F	T
L7	6200005690	S.COIL	ELJRE 18NG-F	T
L9	6200005660	S.COIL	ELJRE 10NG-F	T
L10	6200003270	S.COIL	NL 252018T-R56J	T
L11	6200006980	S.COIL	ELJRE R10G-F	B
L12	6200005700	S.COIL	ELJRE 22NG-F	T
L13	6200010380	S.COIL	ELJRE R15J-F3	T
L15	6200005680	S.COIL	ELJRE 15NG-F	T
L17	6200009890	S.COIL	C2012C-82NG	T
L18	6200003270	S.COIL	NL 252018T-R56J	B
L19	6200005700	S.COIL	ELJRE 22NG-F	T
L20	6200005640	S.COIL	ELJRE 6N8Z-F	T
L21	6200009930	S.COIL	C2012C-68NG	B
L22	6200010060	S.COIL	AS080647-56N	T
L23	6200010040	S.COIL	AS100340-10N	T
L24	6200010210	S.COIL	C2012C-22NG	T
L25	6200010130	S.COIL	LQW18AN6N8C00	T

M.=Mounted side (T: Mounted on the Top side, B: Mounted on the Bottom side)

[MAIN UNIT]

REF NO.	ORDER NO.	DESCRIPTION		M.
L26	6200010630	S.COIL	LQW18AN8N2D00D	T
L27	6200005590	S.COIL	ELJRE 2N7Z-F	T
L28	6200009890	S.COIL	C2012C-82NG	T
L29	6200010060	S.COIL	AS080647-56N	T
L30	6200010160	S.COIL	AS080440-22N	T
L31	6200005590	S.COIL	ELJRE 2N7Z-F	T
L32	6200009930	S.COIL	C2012C-68NG	T
L33	6200010540	S.COIL	C2012C-47NG	T
L34	6200010630	S.COIL	LQW18AN8N2D00D	T
L35	6200010130	S.COIL	LQW18AN6N8C00	T
L36	6200006980	S.COIL	ELJRE R10G-F	T
L37	6200010130	S.COIL	LQW18AN6N8C00	T
L38	6200010130	S.COIL	LQW18AN6N8C00	T
L39	6200005590	S.COIL	ELJRE 2N7Z-F	T
L40	6200010330	S.COIL	C2012C-R18G	T
L41	6200010000	S.COIL	C2012C-56NG	T
L42	6200010420	S.COIL	FHW1210HC 1R0JGT	T
L43	6200010420	S.COIL	FHW1210HC 1R0JGT	T
L44	6200009750	S.COIL	0.30-2.0-7TL 68N	T
L45	6200010060	S.COIL	AS080647-56N	T
L46	6200010050	S.COIL	AS080547-47N	T
L47	6200010160	S.COIL	AS080440-22N	T
L49	6200010050	S.COIL	AS080547-47N	T
L50	6200010160	S.COIL	AS080440-22N	T
L51	6200010040	S.COIL	AS100340-10N	T
L52	6200010160	S.COIL	AS080440-22N	T
L53	6200008170	S.COIL	0.35-1.6-8TL 54N	T
L54	6200008330	S.COIL	0.45-1.4-4TL 15N	T
L55	6200005670	S.COIL	ELJRE 12NG-F	B
L56	6200010150	S.COIL	AS080340-15N	T
L57	6200010070	S.COIL	AS080747-68N	T
L58	6200005660	S.COIL	ELJRE 10NG-F	B
L59	6200010160	S.COIL	AS080440-22N	T
L60	6190001520	S.COIL	ZBF55101-PT	T
L61	6190001520	S.COIL	ZBF55101-PT	T
L62	6190001520	S.COIL	ZBF55101-PT	T
L63	6190001520	S.COIL	ZBF55101-PT	T
L64	6200005140	S.COIL	MLF1608D R33K-T	T
L65	6200005190	S.COIL	MLF1608D R56K-T	T
L66	6200004480	S.COIL	MLF1608D R82K-T	B
L67	6200003540	S.COIL	MLF1608D R22K-T	B
L68	6200003640	S.COIL	MLF1608E 100K-T	T
L69	6200005730	S.COIL	ELJRE 39NG-F	T
R1	7030003680	S.RESISTOR	ERJ3GEYJ 104 V (100 kΩ)	T
R2	7030003560	S.RESISTOR	ERJ3GEYJ 103 V (10 kΩ)	B
R3	7030003840	S.RESISTOR	ERJ3GEYJ 225 V (2.2 MΩ)	T
R4	7030003680	S.RESISTOR	ERJ3GEYJ 104 V (100 kΩ)	T
R5	7030003660	S.RESISTOR	ERJ3GEYJ 683 V (68 kΩ)	T
R6	7030003820	S.RESISTOR	ERJ3GEYJ 155 V (1.5 MΩ)	T
R7	7030003580	S.RESISTOR	ERJ3GEYJ 153 V (15 kΩ)	B
R8	7030003320	S.RESISTOR	ERJ3GEYJ 101 V (100 Ω)	T
R9	7030003640	S.RESISTOR	ERJ3GEYJ 473 V (47 kΩ)	T
R10	7030003450	S.RESISTOR	ERJ3GEYJ 122 V (1.2 kΩ)	T
R11	7030003510	S.RESISTOR	ERJ3GEYJ 392 V (3.9 kΩ)	T
R12	7030003630	S.RESISTOR	ERJ3GEYJ 393 V (39 kΩ)	B
R13	7030003320	S.RESISTOR	ERJ3GEYJ 101 V (100 Ω)	T
R14	7030003680	S.RESISTOR	ERJ3GEYJ 104 V (100 kΩ)	T
R15	7030003680	S.RESISTOR	ERJ3GEYJ 104 V (100 kΩ)	T
R16	7030003500	S.RESISTOR	ERJ3GEYJ 332 V (3.3 kΩ)	T
R17	7030003240	S.RESISTOR	ERJ3GEYJ 220 V (22 Ω)	B
R18	7030003600	S.RESISTOR	ERJ3GEYJ 223 V (22 kΩ)	T
R19	7030003240	S.RESISTOR	ERJ3GEYJ 220 V (22 Ω)	B
R20	7030003600	S.RESISTOR	ERJ3GEYJ 223 V (22 kΩ)	T
R21	7030003400	S.RESISTOR	ERJ3GEYJ 471 V (470 Ω)	T
R22	7030003640	S.RESISTOR	ERJ3GEYJ 473 V (47 kΩ)	T
R23	7030003580	S.RESISTOR	ERJ3GEYJ 153 V (15 kΩ)	T
R24	7030003530	S.RESISTOR	ERJ3GEYJ 562 V (5.6 kΩ)	T
R25	7030003400	S.RESISTOR	ERJ3GEYJ 471 V (470 Ω)	B
R28	7030003560	S.RESISTOR	ERJ3GEYJ 103 V (10 kΩ)	T
R29	7030003680	S.RESISTOR	ERJ3GEYJ 104 V (100 kΩ)	T
R30	7030003600	S.RESISTOR	ERJ3GEYJ 223 V (22 kΩ)	T
R31	7030003500	S.RESISTOR	ERJ3GEYJ 103 V (10 kΩ)	B
R32	7030003630	S.RESISTOR	ERJ3GEYJ 393 V (39 kΩ)	B
R33	7030003580	S.RESISTOR	ERJ3GEYJ 153 V (15 kΩ)	T
R34	7030003340	S.RESISTOR	ERJ3GEYJ 151 V (150 Ω)	T
R35	7030003600	S.RESISTOR	ERJ3GEYJ 223 V (22 kΩ)	T
R36	7030003320	S.RESISTOR	ERJ3GEYJ 101 V (100 Ω)	T
R37	7030003500	S.RESISTOR	ERJ3GEYJ 332 V (3.3 kΩ)	T
R38	7030003680	S.RESISTOR	ERJ3GEYJ 104 V (100 kΩ)	T

S.=Surface mount

[MAIN UNIT]

REF NO.	ORDER NO.	DESCRIPTION		M.
R39	7030003680	S.RESISTOR	ERJ3GEYJ 104 V (100 kΩ)	T
R40	7030003700	S.RESISTOR	ERJ3GEYJ 154 V (150 kΩ)	B
R41	7030003720	S.RESISTOR	ERJ3GEYJ 224 V (220 kΩ)	T
R42	7030003580	S.RESISTOR	ERJ3GEYJ 153 V (15 kΩ)	B
R43	7030003560	S.RESISTOR	ERJ3GEYJ 103 V (10 kΩ)	T
R44	7030003520	S.RESISTOR	ERJ3GEYJ 472 V (4.7 kΩ)	T
R45	7030003720	S.RESISTOR	ERJ3GEYJ 224 V (220 kΩ)	B
R46	7030003380	S.RESISTOR	ERJ3GEYJ 331 V (330 Ω)	T
R47	7030003730	S.RESISTOR	ERJ3GEYJ 274 V (270 kΩ)	B
R48	7030003440	S.RESISTOR	ERJ3GEYJ 102 V (1 kΩ)	T
R49	7030003660	S.RESISTOR	ERJ3GEYJ 683 V (68 kΩ)	T
R50	7030003780	S.RESISTOR	ERJ3GEYJ 684 V (680 kΩ)	T
R51	7030003660	S.RESISTOR	ERJ3GEYJ 683 V (68 kΩ)	T
R52	7030003560	S.RESISTOR	ERJ3GEYJ 103 V (10 kΩ)	T
R53	7030003680	S.RESISTOR	ERJ3GEYJ 104 V (100 kΩ)	T
R54	7030003560	S.RESISTOR	ERJ3GEYJ 103 V (10 kΩ)	T
R55	7030003560	S.RESISTOR	ERJ3GEYJ 103 V (10 kΩ)	T
R56	7030003660	S.RESISTOR	ERJ3GEYJ 683 V (68 kΩ)	T
R57	7030003630	S.RESISTOR	ERJ3GEYJ 393 V (39 kΩ)	T
R58	7030003660	S.RESISTOR	ERJ3GEYJ 683 V (68 kΩ)	B
R59	7030003600	S.RESISTOR	ERJ3GEYJ 223 V (22 kΩ)	B
R60	7030003560	S.RESISTOR	ERJ3GEYJ 103 V (10 kΩ)	T
R61	7030003560	S.RESISTOR	ERJ3GEYJ 103 V (10 kΩ)	T
R62	7030003610	S.RESISTOR	ERJ3GEYJ 273 V (27 kΩ)	T
R63	7030003610	S.RESISTOR	ERJ3GEYJ 273 V (27 kΩ)	T
R64	7030003560	S.RESISTOR	ERJ3GEYJ 103 V (10 kΩ)	T
R65	7030003610	S.RESISTOR	ERJ3GEYJ 273 V (27 kΩ)	T
R66	7030003560	S.RESISTOR	ERJ3GEYJ 103 V (10 kΩ)	T
R67	7030003600	S.RESISTOR	ERJ3GEYJ 223 V (22 kΩ)	T
R68	7030003460	S.RESISTOR	ERJ3GEYJ 152 V (1.5 kΩ)	B
R69	7030003540	S.RESISTOR	ERJ3GEYJ 682 V (6.8 kΩ)	T
R70	7030003520	S.RESISTOR	ERJ3GEYJ 472 V (4.7 kΩ)	T
R71	7030003590	S.RESISTOR	ERJ3GEYJ 183 V (18 kΩ)	T
R72	7030003560	S.RESISTOR	ERJ3GEYJ 103 V (10 kΩ)	T
R73	7030003460	S.RESISTOR	ERJ3GEYJ 152 V (1.5 kΩ)	B
R74	7030003570	S.RESISTOR	ERJ3GEYJ 123 V (12 kΩ)	T
R75	7030003690	S.RESISTOR	ERJ3GEYJ 124 V (120 kΩ)	T
R76	7030003320	S.RESISTOR	ERJ3GEYJ 101 V (100 Ω)	B
R77	7030003510	S.RESISTOR	ERJ3GEYJ 392 V (3.9 kΩ)	T
R78	7030003320	S.RESISTOR	ERJ3GEYJ 101 V (100 Ω)	T
R79	7030003320	S.RESISTOR	ERJ3GEYJ 101 V (100 Ω)	B
R80	7030003840	S.RESISTOR	ERJ3GEYJ 225 V (2.2 MΩ)	T
R81	7030003710	S.RESISTOR	ERJ3GEYJ 184 V (180 kΩ)	T
R82	7030003320	S.RESISTOR	ERJ3GEYJ 101 V (100 Ω)	B
R83	7030003460	S.RESISTOR	ERJ3GEYJ 152 V (1.5 kΩ)	T
R84	7030003320	S.RESISTOR	ERJ3GEYJ 101 V (100 Ω)	T
R85	7030003450	S.RESISTOR	ERJ3GEYJ 122 V (1.2 kΩ)	T
R86	7030003600	S.RESISTOR	ERJ3GEYJ 223 V (22 kΩ)	B
R87	7030003760	S.RESISTOR	ERJ3GEYJ 474 V (470 kΩ)	B
R88	7030003720	S.RESISTOR	ERJ3GEYJ 224 V (220 kΩ)	B
R89	7030003450	S.RESISTOR	ERJ3GEYJ 122 V (1.2 kΩ)	T
R90	7030003420	S.RESISTOR	ERJ3GEYJ 681 V (680 Ω)	T
R91	7030003710	S.RESISTOR	ERJ3GEYJ 184 V (180 kΩ)	B
R92	7030003620	S.RESISTOR	ERJ3GEYJ 333 V (33 kΩ)	B
R93	7030003840	S.RESISTOR	ERJ3GEYJ 225 V (2.2 MΩ)	T
R94	7030003590	S.RESISTOR	ERJ3GEYJ 183 V (18 kΩ)	B
R95	7030003560	S.RESISTOR	ERJ3GEYJ 103 V (10 kΩ)	B
R96	7030003340	S.RESISTOR	ERJ3GEYJ 151 V (150 Ω)	T
R97	7030003840	S.RESISTOR	ERJ3GEYJ 225 V (2.2 MΩ)	B
R98	7030003560	S.RESISTOR	ERJ3GEYJ 103 V (10 kΩ)	B
R100	7030003740	S.RESISTOR	ERJ3GEYJ 334 V (330 kΩ)	T
R101	7030003480	S.RESISTOR	ERJ3GEYJ 222 V (2.2 kΩ)	B
R102	7030000120	S.RESISTOR	MCR10EZJH 6.8 Ω (6R8)	T
R103	7030000190	S.RESISTOR	MCR10EZJH 27 Ω (270)	B
R104	7030003450	S.RESISTOR	ERJ3GEYJ 122 V (1.2 kΩ)	T
R105	7030003450	S.RESISTOR	ERJ3GEYJ 122 V (1.2 kΩ)	T
R106	7030003510	S.RESISTOR	ERJ3GEYJ 392 V (3.9 kΩ)	T
R107	7030003380	S.RESISTOR	ERJ3GEYJ 331 V (330 Ω)	T
R108	7030003440	S.RESISTOR	ERJ3GEYJ 102 V (1 kΩ)	B
R109	7030003710	S.RESISTOR	ERJ3GEYJ 184 V (180 kΩ)	B
R110	7030003730	S.RESISTOR	ERJ3GEYJ 274 V (270 kΩ)	B
R111	7030003400	S.RESISTOR	ERJ3GEYJ 471 V (470 Ω)	B
R112	7030003560	S.RESISTOR	ERJ3GEYJ 103 V (10 kΩ)	B
R113	7030000190	S.RESISTOR	MCR10EZJH 27 Ω (270)	B
R114	7030003400	S.RESISTOR	ERJ3GEYJ 471 V (470 Ω)	B
R115	7030003280	S.RESISTOR	ERJ3GEYJ 470 V (47 Ω)	B
R117	7030003370	S.RESISTOR	ERJ3GEYJ 271 V (270 Ω)	B
R118	7030003680	S.RESISTOR	ERJ3GEYJ 104 V (100 kΩ)	B
R119	7030003380	S.RESISTOR	ERJ3GEYJ 331 V (330 Ω)	B
R120	7030003440	S.RESISTOR	ERJ3GEYJ 102 V (1 kΩ)	T
R121	7030003560	S.RESISTOR	ERJ3GEYJ 103 V (10 kΩ)	B

M.=Mounted side (T: Mounted on the Top side, B: Mounted on the Bottom side)

[MAIN UNIT]

REF NO.	ORDER NO.	DESCRIPTION		M.
R122	7030003500	S.RESISTOR	ERJ3GEYJ 332 V (3.3 kΩ)	B
R123	7030003500	S.RESISTOR	ERJ3GEYJ 332 V (3.3 kΩ)	T
R124	7030003440	S.RESISTOR	ERJ3GEYJ 102 V (1 kΩ)	T
R125	7030003440	S.RESISTOR	ERJ3GEYJ 102 V (1 kΩ)	B
R126	7030003370	S.RESISTOR	ERJ3GEYJ 271 V (270 Ω)	B
R127	7030003640	S.RESISTOR	ERJ3GEYJ 473 V (47 kΩ)	T
R128	7030003640	S.RESISTOR	ERJ3GEYJ 473 V (47 kΩ)	B
R129	7030003600	S.RESISTOR	ERJ3GEYJ 223 V (22 kΩ)	T
R130	7030003480	S.RESISTOR	ERJ3GEYJ 222 V (2.2 kΩ)	B
R131	7030003480	S.RESISTOR	ERJ3GEYJ 222 V (2.2 kΩ)	T
R132	7030003370	S.RESISTOR	ERJ3GEYJ 271 V (270 Ω)	T
R133	7030003270	S.RESISTOR	ERJ3GEYJ 390 V (39 Ω)	B
R134	7030003340	S.RESISTOR	ERJ3GEYJ 151 V (150 Ω)	B
R135	7030003220	S.RESISTOR	ERJ3GEYJ 150 V (15 Ω)	T
R136	7030003380	S.RESISTOR	ERJ3GEYJ 331 V (330 Ω)	T
R137	7030003340	S.RESISTOR	ERJ3GEYJ 151 V (150 Ω)	B
R138	7030003380	S.RESISTOR	ERJ3GEYJ 331 V (330 Ω)	T
R139	7030000270	S.RESISTOR	MCR10EZJH 120 Ω (121)	B
R140	7030003520	S.RESISTOR	ERJ3GEYJ 472 V (4.7 kΩ)	B
R141	7030003440	S.RESISTOR	ERJ3GEYJ 102 V (1 kΩ)	B
R142	7030003520	S.RESISTOR	ERJ3GEYJ 472 V (4.7 kΩ)	T
R143	7030003420	S.RESISTOR	ERJ3GEYJ 681 V (680 Ω)	T
R145	7030003280	S.RESISTOR	ERJ3GEYJ 470 V (47 Ω)	T
R146	7030003480	S.RESISTOR	ERJ3GEYJ 222 V (2.2 kΩ)	T
R147	7030003320	S.RESISTOR	ERJ3GEYJ 101 V (100 Ω)	T
R148	7030003480	S.RESISTOR	ERJ3GEYJ 222 V (2.2 kΩ)	T
R149	7030003480	S.RESISTOR	ERJ3GEYJ 222 V (2.2 kΩ)	B
R150	7030003480	S.RESISTOR	ERJ3GEYJ 222 V (2.2 kΩ)	T
R151	7030003240	S.RESISTOR	ERJ3GEYJ 220 V (22 Ω)	T
R154	7030000180	S.RESISTOR	MCR10EZJH 22 Ω (220)	T
R155	7030003440	S.RESISTOR	ERJ3GEYJ 102 V (1 kΩ)	T
R157	7030003520	S.RESISTOR	ERJ3GEYJ 472 V (4.7 kΩ)	B
R158	7030003440	S.RESISTOR	ERJ3GEYJ 102 V (1 kΩ)	T
R159	7030003520	S.RESISTOR	ERJ3GEYJ 472 V (4.7 kΩ)	T
R160	7030003420	S.RESISTOR	ERJ3GEYJ 681 V (680 Ω)	T
R161	7030003360	S.RESISTOR	ERJ3GEYJ 221 V (220 Ω)	T
R162	7030003520	S.RESISTOR	ERJ3GEYJ 472 V (4.7 kΩ)	B
R163	7030003520	S.RESISTOR	ERJ3GEYJ 472 V (4.7 kΩ)	T
R164	7030000180	S.RESISTOR	MCR10EZJH 22 Ω (220)	T
R165	7030000180	S.RESISTOR	MCR10EZJH 22 Ω (220)	T
R167	7030003370	S.RESISTOR	ERJ3GEYJ 271 V (270 Ω)	T
R168	7030003480	S.RESISTOR	ERJ3GEYJ 222 V (2.2 kΩ)	B
R169	7030003320	S.RESISTOR	ERJ3GEYJ 101 V (100 Ω)	B
R170	7030004050	S.RESISTOR	ERJ3GEYJ 1R0 V (1 Ω)	B
R171	7030003480	S.RESISTOR	ERJ3GEYJ 222 V (2.2 kΩ)	T
R172	7030003480	S.RESISTOR	ERJ3GEYJ 222 V (2.2 kΩ)	T
R173	7030003480	S.RESISTOR	ERJ3GEYJ 222 V (2.2 kΩ)	T
R174	7030003220	S.RESISTOR	ERJ3GEYJ 150 V (15 Ω)	B
R175	7030003320	S.RESISTOR	ERJ3GEYJ 101 V (100 Ω)	B
R176	7030003230	S.RESISTOR	ERJ3GEYJ 180 V (18 Ω)	T
R177	7030003360	S.RESISTOR	ERJ3GEYJ 221 V (220 Ω)	T
R178	7030003440	S.RESISTOR	ERJ3GEYJ 102 V (1 kΩ)	B
R180	7030003360	S.RESISTOR	ERJ3GEYJ 221 V (220 Ω)	T
R181	7030003720	S.RESISTOR	ERJ3GEYJ 224 V (220 kΩ)	T
R182	7030003360	S.RESISTOR	ERJ3GEYJ 221 V (220 Ω)	B
R183	7030003360	S.RESISTOR	ERJ3GEYJ 221 V (220 Ω)	T
R185	7030003560	S.RESISTOR	ERJ3GEYJ 103 V (10 kΩ)	B
R186	7030003650	S.RESISTOR	ERJ3GEYJ 563 V (56 kΩ)	T
R188	7030003360	S.RESISTOR	ERJ3GEYJ 221 V (220 Ω)	T
R189	7030003720	S.RESISTOR	ERJ3GEYJ 224 V (220 kΩ)	T
R190	7030003560	S.RESISTOR	ERJ3GEYJ 103 V (10 kΩ)	T
R191	7030003560	S.RESISTOR	ERJ3GEYJ 103 V (10 kΩ)	T
R192	7030003240	S.RESISTOR	ERJ3GEYJ 220 V (22 Ω)	T
R194	7030003680	S.RESISTOR	ERJ3GEYJ 104 V (100 kΩ)	T
R195	7030003720	S.RESISTOR	ERJ3GEYJ 224 V (220 kΩ)	T
R196	7030003680	S.RESISTOR	ERJ3GEYJ 104 V (100 kΩ)	T
R197	7030003680	S.RESISTOR	ERJ3GEYJ 104 V (100 kΩ)	T
R198	7030003680	S.RESISTOR	ERJ3GEYJ 104 V (100 kΩ)	T
R199	7030003200	S.RESISTOR	ERJ3GEYJ 100 V (10 Ω)	T
R200	7030003680	S.RESISTOR	ERJ3GEYJ 104 V (100 kΩ)	T
R201	7030003200	S.RESISTOR	ERJ3GEYJ 100 V (10 Ω)	T
R202	7030003610	S.RESISTOR	ERJ3GEYJ 273 V (27 kΩ)	B
R203	7030003600	S.RESISTOR	ERJ3GEYJ 223 V (22 kΩ)	B
R204	7030003440	S.RESISTOR	ERJ3GEYJ 102 V (1 kΩ)	T
R205	7030003680	S.RESISTOR	ERJ3GEYJ 104 V (100 kΩ)	T
R206	7030003510	S.RESISTOR	ERJ3GEYJ 392 V (3.9 kΩ)	T
R207	7030003280	S.RESISTOR	ERJ3GEYJ 470 V (47 Ω)	T
R208	7030003320	S.RESISTOR	ERJ3GEYJ 101 V (100 Ω)	T
R209	7030003320	S.RESISTOR	ERJ3GEYJ 101 V (100 Ω)	T
R210	7030003510	S.RESISTOR	ERJ3GEYJ 392 V (3.9 kΩ)	T
R211	7030003440	S.RESISTOR	ERJ3GEYJ 102 V (1 kΩ)	T

S.=Surface mount

[MAIN UNIT]

REF NO.	ORDER NO.	DESCRIPTION		M.
R212	7030003720	S.RESISTOR	ERJ3GEYJ 224 V (220 kΩ)	T
R213	7030003440	S.RESISTOR	ERJ3GEYJ 102 V (1 kΩ)	T
R214	7030003360	S.RESISTOR	ERJ3GEYJ 221 V (220 Ω)	T
R217	7030003640	S.RESISTOR	ERJ3GEYJ 473 V (47 kΩ)	T
R218	7030003680	S.RESISTOR	ERJ3GEYJ 104 V (100 kΩ)	T
R219	7030003680	S.RESISTOR	ERJ3GEYJ 104 V (100 kΩ)	T
R220	7030003640	S.RESISTOR	ERJ3GEYJ 473 V (47 kΩ)	T
R221	7030003620	S.RESISTOR	ERJ3GEYJ 333 V (33 kΩ)	T
R222	7030003560	S.RESISTOR	ERJ3GEYJ 103 V (10 kΩ)	T
R223	7030003620	S.RESISTOR	ERJ3GEYJ 333 V (33 kΩ)	T
R224	7030003600	S.RESISTOR	ERJ3GEYJ 223 V (22 kΩ)	T
R225	7030003560	S.RESISTOR	ERJ3GEYJ 103 V (10 kΩ)	B
R226	7030003620	S.RESISTOR	ERJ3GEYJ 333 V (33 kΩ)	T
R228	7030003560	S.RESISTOR	ERJ3GEYJ 103 V (10 kΩ)	T
R229	7030003800	S.RESISTOR	ERJ3GEYJ 105 V (1 MΩ)	T
R230	7030003560	S.RESISTOR	ERJ3GEYJ 103 V (10 kΩ)	T
R231	7030003680	S.RESISTOR	ERJ3GEYJ 104 V (100 kΩ)	T
R232	7030003680	S.RESISTOR	ERJ3GEYJ 104 V (100 kΩ)	T
R233	7030003480	S.RESISTOR	ERJ3GEYJ 222 V (2.2 kΩ)	B
R234	7030003710	S.RESISTOR	ERJ3GEYJ 184 V (180 kΩ)	B
R235	7030003740	S.RESISTOR	ERJ3GEYJ 334 V (330 kΩ)	B
R236	7030003600	S.RESISTOR	ERJ3GEYJ 223 V (22 kΩ)	B
R237	7030006070	S.RESISTOR	ERJ12YJ101U (100 Ω)	B
R238	7030003580	S.RESISTOR	ERJ3GEYJ 153 V (15 kΩ)	B
R239	7030003720	S.RESISTOR	ERJ3GEYJ 224 V (220 kΩ)	T
R240	7030003440	S.RESISTOR	ERJ3GEYJ 102 V (1 kΩ)	T
R241	7030003480	S.RESISTOR	ERJ3GEYJ 222 V (2.2 kΩ)	T
R242	7030003480	S.RESISTOR	ERJ3GEYJ 222 V (2.2 kΩ)	T
R243	7030003560	S.RESISTOR	ERJ3GEYJ 103 V (10 kΩ)	T
R244	7030003440	S.RESISTOR	ERJ3GEYJ 102 V (1 kΩ)	T
R245	7030003480	S.RESISTOR	ERJ3GEYJ 222 V (2.2 kΩ)	T
R246	7030006070	S.RESISTOR	ERJ12YJ101U (100 Ω)	T
R247	7030003480	S.RESISTOR	ERJ3GEYJ 222 V (2.2 kΩ)	T
R248	7030003520	S.RESISTOR	ERJ3GEYJ 472 V (4.7 kΩ)	T
R249	7030003540	S.RESISTOR	ERJ3GEYJ 682 V (6.8 kΩ)	T
R250	7030003740	S.RESISTOR	ERJ3GEYJ 334 V (330 kΩ)	B
R251	7030003540	S.RESISTOR	ERJ3GEYJ 682 V (6.8 kΩ)	T
R252	7030003560	S.RESISTOR	ERJ3GEYJ 103 V (10 kΩ)	B
R253	7030003480	S.RESISTOR	ERJ3GEYJ 222 V (2.2 kΩ)	B
R254	7030003710	S.RESISTOR	ERJ3GEYJ 184 V (180 kΩ)	T
R255	7030003620	S.RESISTOR	ERJ3GEYJ 333 V (33 kΩ)	B
R256	7030003720	S.RESISTOR	ERJ3GEYJ 224 V (220 kΩ)	T
R257	7030003560	S.RESISTOR	ERJ3GEYJ 103 V (10 kΩ)	T
R258	7030003440	S.RESISTOR	ERJ3GEYJ 102 V (1 kΩ)	T
R259	7030003340	S.RESISTOR	ERJ3GEYJ 151 V (150 Ω)	T
R260	7030003670	S.RESISTOR	ERJ3GEYJ 823 V (82 kΩ)	B
R501	7030003440	S.RESISTOR	ERJ3GEYJ 102 V (1 kΩ)	B
R502	7030003640	S.RESISTOR	ERJ3GEYJ 473 V (47 kΩ)	B
R503	7030003570	S.RESISTOR	ERJ3GEYJ 123 V (12 kΩ)	B
R504	7030003570	S.RESISTOR	ERJ3GEYJ 123 V (12 kΩ)	B
R505	7030003520	S.RESISTOR	ERJ3GEYJ 472 V (4.7 kΩ)	B
R506	7030003570	S.RESISTOR	ERJ3GEYJ 123 V (12 kΩ)	B
R507	7030003680	S.RESISTOR	ERJ3GEYJ 104 V (100 kΩ)	T
R508	7030003640	S.RESISTOR	ERJ3GEYJ 473 V (47 kΩ)	T
R509	7030000400	S.RESISTOR	MCR10EZJH 1.5 kΩ	T
R510	7030003440	S.RESISTOR	ERJ3GEYJ 102 V (1 kΩ)	T
R511	7030003800	S.RESISTOR	ERJ3GEYJ 105 V (1 MΩ)	B
R512	7030003560	S.RESISTOR	ERJ3GEYJ 103 V (10 kΩ)	T
R513	7030000020	S.RESISTOR	MCR10EZJH 1 Ω (010)	T
R514	7030003640	S.RESISTOR	ERJ3GEYJ 473 V (47 kΩ)	T
R515	7030003440	S.RESISTOR	ERJ3GEYJ 102 V (1 kΩ)	T
R516	7030003560	S.RESISTOR	ERJ3GEYJ 103 V (10 kΩ)	B
R517	7030003320	S.RESISTOR	ERJ3GEYJ 101 V (100 Ω)	T
R518	7030003440	S.RESISTOR	ERJ3GEYJ 102 V (1 kΩ)	B
R520	7030003320	S.RESISTOR	ERJ3GEYJ 101 V (100 Ω)	B
R521	7030003440	S.RESISTOR	ERJ3GEYJ 102 V (1 kΩ)	T
R522	7030003520	S.RESISTOR	ERJ3GEYJ 472 V (4.7 kΩ)	T
R523	7030003520	S.RESISTOR	ERJ3GEYJ 472 V (4.7 kΩ)	B
R524	7030003680	S.RESISTOR	ERJ3GEYJ 104 V (100 kΩ)	B
R525	7030003520	S.RESISTOR	ERJ3GEYJ 472 V (4.7 kΩ)	B
R526	7030003560	S.RESISTOR	ERJ3GEYJ 103 V (10 kΩ)	B
R527	7030003440	S.RESISTOR	ERJ3GEYJ 102 V (1 kΩ)	B
R528	7030003520	S.RESISTOR	ERJ3GEYJ 472 V (4.7 kΩ)	T
R529	7030003640	S.RESISTOR	ERJ3GEYJ 473 V (47 kΩ)	B
R530	7410000800	S.ARRAY	EXB-V8V 103JV (10 kΩ)	T
R531	7030003560	S.RESISTOR	ERJ3GEYJ 103 V (10 kΩ)	T
R532	7030003700	S.RESISTOR	ERJ3GEYJ 154 V (150 kΩ)	B
R533	7030003680	S.RESISTOR	ERJ3GEYJ 104 V (100 kΩ)	B
R534	7030003680	S.RESISTOR	ERJ3GEYJ 104 V (100 kΩ)	B
R535	7510001470	S.THERMISTOR	NTCG20 4AG 473JT	T
R536	7030003680	S.RESISTOR	ERJ3GEYJ 104 V (100 kΩ)	T

M.=Mounted side (T: Mounted on the Top side, B: Mounted on the Bottom side)

[MAIN UNIT]

REF NO.	ORDER NO.	DESCRIPTION		M.
R537	7030003520	S.RESISTOR	ERJ3GEYJ 472 V (4.7 kΩ)	T
R538	7030003620	S.RESISTOR	ERJ3GEYJ 333 V (33 kΩ)	T
R539	7030003660	S.RESISTOR	ERJ3GEYJ 683 V (68 kΩ)	T
R540	7030003520	S.RESISTOR	ERJ3GEYJ 472 V (4.7 kΩ)	T
R541	7030003320	S.RESISTOR	ERJ3GEYJ 101 V (100 Ω)	B
R542	7030003530	S.RESISTOR	ERJ3GEYJ 562 V (5.6 kΩ)	T
R543	7030003320	S.RESISTOR	ERJ3GEYJ 101 V (100 Ω)	T
R544	7030003320	S.RESISTOR	ERJ3GEYJ 101 V (100 Ω)	B
R545	7030003320	S.RESISTOR	ERJ3GEYJ 101 V (100 Ω)	B
R546	7410001090	S.ARRAY	EXB-V8V 101JV	T
R547	7030003590	S.RESISTOR	ERJ3GEYJ 183 V (18 kΩ)	T
R548	7030003700	S.RESISTOR	ERJ3GEYJ 154 V (150 kΩ)	B
R549	7030003600	S.RESISTOR	ERJ3GEYJ 223 V (22 kΩ)	T
R550	7030003580	S.RESISTOR	ERJ3GEYJ 153 V (15 kΩ)	T
R551	7030003320	S.RESISTOR	ERJ3GEYJ 101 V (100 Ω)	B
R552	7030004050	S.RESISTOR	ERJ3GEYJ 1R0 V (1 Ω)	T
R553	7030003320	S.RESISTOR	ERJ3GEYJ 101 V (100 Ω)	B
R554	7030003760	S.RESISTOR	ERJ3GEYJ 474 V (470 kΩ)	T
R555	7030003600	S.RESISTOR	ERJ3GEYJ 223 V (22 kΩ)	T
R556	7030003560	S.RESISTOR	ERJ3GEYJ 103 V (10 kΩ)	T
R557	7030003320	S.RESISTOR	ERJ3GEYJ 101 V (100 Ω)	T
R558	7030003320	S.RESISTOR	ERJ3GEYJ 101 V (100 Ω)	T
R559	7410001090	S.ARRAY	EXB-V8V 101JV	T
R561	7030003480	S.RESISTOR	ERJ3GEYJ 222 V (2.2 kΩ)	T
R562	7030003680	S.RESISTOR	ERJ3GEYJ 104 V (100 kΩ)	T
R563	7410001090	S.ARRAY	EXB-V8V 101JV	T
R564	7030005521	S.RESISTOR	ERA3YKD 334V (330 kΩ)	B
R565	7030005501	S.RESISTOR	ERA3YKD 124V (120 kΩ)	B
R566	7030005691	S.RESISTOR	ERA3YED 123V	B
R567	7030003560	S.RESISTOR	ERJ3GEYJ 103 V (10 kΩ)	B
R568	7030003320	S.RESISTOR	ERJ3GEYJ 101 V (100 Ω)	T
R569	7030003760	S.RESISTOR	ERJ3GEYJ 474 V (470 kΩ)	T
R570	7410001090	S.ARRAY	EXB-V8V 101JV	B
R571	7410001090	S.ARRAY	EXB-V8V 101JV	T
R574	7030003320	S.RESISTOR	ERJ3GEYJ 101 V (100 Ω)	T
R575	7030003320	S.RESISTOR	ERJ3GEYJ 101 V (100 Ω)	T
R576	7030003320	S.RESISTOR	ERJ3GEYJ 101 V (100 Ω)	T
R577	7410001090	S.ARRAY	EXB-V8V 101JV	T
R578	7410001090	S.ARRAY	EXB-V8V 101JV	B
R579	7030003440	S.RESISTOR	ERJ3GEYJ 102 V (1 kΩ)	T
R580	7030003640	S.RESISTOR	ERJ3GEYJ 473 V (47 kΩ)	T
R581	7030003680	S.RESISTOR	ERJ3GEYJ 104 V (100 kΩ)	T
R582	7030003520	S.RESISTOR	ERJ3GEYJ 472 V (4.7 kΩ)	T
R583	7030003530	S.RESISTOR	ERJ3GEYJ 562 V (5.6 kΩ)	T
	7030003550	S.RESISTOR	ERJ3GEYJ 822 V (8.2 kΩ) except [USA]	T
R584	7030003550	S.RESISTOR	ERJ3GEYJ 822 V (8.2 kΩ) [USA] only	T
	7030003610	S.RESISTOR	ERJ3GEYJ 273 V (27 kΩ) except [USA]	T
			[USA] only	T
R585	7030003520	S.RESISTOR	ERJ3GEYJ 472 V (4.7 kΩ)	T
R586	7030003580	S.RESISTOR	ERJ3GEYJ 153 V (15 kΩ)	T
R587	7030003500	S.RESISTOR	ERJ3GEYJ 332 V (3.3 kΩ)	T
R588	7030003640	S.RESISTOR	ERJ3GEYJ 473 V (47 kΩ)	T
R589	7030003680	S.RESISTOR	ERJ3GEYJ 104 V (100 kΩ)	T
R590	7030003640	S.RESISTOR	ERJ3GEYJ 473 V (47 kΩ)	T
R591	7030003680	S.RESISTOR	ERJ3GEYJ 104 V (100 kΩ)	T
R592	7030003840	S.RESISTOR	ERJ3GEYJ 225 V (2.2 MΩ)	T
R593	7030003620	S.RESISTOR	ERJ3GEYJ 333 V (33 kΩ)	T
R594	7030003840	S.RESISTOR	ERJ3GEYJ 225 V (2.2 MΩ)	T
R595	7030003680	S.RESISTOR	ERJ3GEYJ 104 V (100 kΩ)	T
R596	7030003560	S.RESISTOR	ERJ3GEYJ 103 V (10 kΩ)	T
R597	7030003640	S.RESISTOR	ERJ3GEYJ 473 V (47 kΩ)	T
R598	7030003520	S.RESISTOR	ERJ3GEYJ 472 V (4.7 kΩ)	T
R599	7030003840	S.RESISTOR	ERJ3GEYJ 225 V (2.2 MΩ)	T
R600	7030003840	S.RESISTOR	ERJ3GEYJ 225 V (2.2 MΩ)	T
R601	7030003760	S.RESISTOR	ERJ3GEYJ 474 V (470 kΩ)	T
R602	7030003840	S.RESISTOR	ERJ3GEYJ 225 V (2.2 MΩ)	T
R603	7030003840	S.RESISTOR	ERJ3GEYJ 225 V (2.2 MΩ)	T
R604	7030000100	S.RESISTOR	MCR10EZJH 4.7 Ω (4R7)	T
R605	7030003560	S.RESISTOR	ERJ3GEYJ 103 V (10 kΩ)	T
R606	7030003840	S.RESISTOR	ERJ3GEYJ 225 V (2.2 MΩ)	B
R607	7030003520	S.RESISTOR	ERJ3GEYJ 472 V (4.7 kΩ)	T
R611	7030003340	S.RESISTOR	ERJ3GEYJ 151 V (150 Ω)	B
R612	7030003470	S.RESISTOR	ERJ3GEYJ 182 V (1.8 kΩ)	B
R615	7030003320	S.RESISTOR	ERJ3GEYJ 101 V (100 Ω)	T
R616	7030003320	S.RESISTOR	ERJ3GEYJ 101 V (100 Ω)	T
R618	7030003360	S.RESISTOR	ERJ3GEYJ 221 V (220 Ω)	B
R619	7030003470	S.RESISTOR	ERJ3GEYJ 182 V (1.8 kΩ)	B
R620	7030003280	S.RESISTOR	ERJ3GEYJ 470 V (47 Ω)	T

S.=Surface mount

[MAIN UNIT]

REF NO.	ORDER NO.	DESCRIPTION	M.
R621	7030003640	S.RESISTOR ERJ3GGEYJ 473 V (47 kΩ)	T
R622	7030003660	S.RESISTOR ERJ3GGEYJ 683 V (68 kΩ)	B
R623	7030003680	S.RESISTOR ERJ3GGEYJ 104 V (100 kΩ)	B
R624	7030003800	S.RESISTOR ERJ3GGEYJ 105 V (1 MΩ)	B
R625	7030003520	S.RESISTOR ERJ3GGEYJ 472 V (4.7 kΩ)	B
R626	7030003520	S.RESISTOR ERJ3GGEYJ 472 V (4.7 kΩ)	B
R627	7030003560	S.RESISTOR ERJ3GGEYJ 103 V (10 kΩ)	B
R628	7030003740	S.RESISTOR ERJ3GGEYJ 334 V (330 kΩ)	T
R629	7030003740	S.RESISTOR ERJ3GGEYJ 334 V (330 kΩ)	T
R630	7030003680	S.RESISTOR ERJ3GGEYJ 104 V (100 kΩ)	T
R631	7030005501	S.RESISTOR ERA3YKD 124V (120 kΩ)	T
R632	7030005501	S.RESISTOR ERA3YKD 124V (120 kΩ)	T
R633	7030003680	S.RESISTOR ERJ3GGEYJ 104 V (100 kΩ)	T
R634	7030005981	S.RESISTOR ERA3YED 333V	T
R635	7030005981	S.RESISTOR ERA3YED 333V	T
R636	7030003740	S.RESISTOR ERJ3GGEYJ 334 V (330 kΩ)	T
R637	7030003730	S.RESISTOR ERJ3GGEYJ 274 V (270 kΩ)	T
R638	7030003730	S.RESISTOR ERJ3GGEYJ 274 V (270 kΩ)	T
R639	7030003720	S.RESISTOR ERJ3GGEYJ 224 V (220 kΩ)	T
R641	7030003360	S.RESISTOR ERJ3GGEYJ 221 V (220 Ω)	B
R642	7030003460	S.RESISTOR ERJ3GGEYJ 152 V (1.5 kΩ)	T
R643	7030003300	S.RESISTOR ERJ3GGEYJ 680 V (68 Ω)	B
R645	7030003220	S.RESISTOR ERJ3GGEYJ 150 V (15 Ω)	B
R646	7030003360	S.RESISTOR ERJ3GGEYJ 221 V (220 Ω)	B
R647	7510001720	S.THEMISTOR TN10-3K222JT	T
R648	7030003510	S.RESISTOR ERJ3GGEYJ 392 V (3.9 kΩ)	B
C1	4030006860	S.CERAMIC C1608 JB 1H 102K-T	B
C2	4030006900	S.CERAMIC C1608 JB 1H 103K-T	T
C3	4030006900	S.CERAMIC C1608 JB 1H 103K-T	T
C4	4030006860	S.CERAMIC C1608 JB 1H 102K-T	T
C5	4030008920	S.CERAMIC C1608 JB 1H 473K-T	B
C6	4030009920	S.CERAMIC C1608 CH 1H 050B-T	T
C7	4030008770	S.CERAMIC C1608 JB 1H 562K-T	T
C8	4030007070	S.CERAMIC C1608 CH 1H 330J-T	B
C9	4030009920	S.CERAMIC C1608 CH 1H 050B-T	T
C10	4030008900	S.CERAMIC C1608 JB 1H 333K-T	T
C11	4030010770	S.CERAMIC C1608 JB 1H 392K-T	T
C12	4550006210	S.TANTALUM ECST1CX106R	T
C13	4030007060	S.CERAMIC C1608 CH 1H 270J-T	T
C14	4030011600	S.CERAMIC C1608 JB 1E 104K-T	B
C15	4030011600	S.CERAMIC C1608 JB 1E 104K-T	T
C16	4030011600	S.CERAMIC C1608 JB 1E 104K-T	B
C17	4030011600	S.CERAMIC C1608 JB 1E 104K-T	T
C18	4030012660	S.CERAMIC C1608 JB 1E 683K-T	B
C19	4030012660	S.CERAMIC C1608 JB 1E 683K-T	B
C20	4030006860	S.CERAMIC C1608 JB 1H 102K-T	T
C21	4030009970	S.CERAMIC C1608 JB 1H 182K-T	T
C22	4030006920	S.CERAMIC C1608 CH 1H 010C-T	T
C23	4030006850	S.CERAMIC C1608 JB 1H 471K-T	B
C24	4030006850	S.CERAMIC C1608 JB 1H 471K-T	B
C25	4030008880	S.CERAMIC C1608 JB 1H 223K-T	T
C26	4030006870	S.CERAMIC C1608 JB 1H 222K-T	T
C27	4510007300	S.ELECTROLYTIC 50 CV 1 BS	T
C28	4030007090	S.CERAMIC C1608 CH 1H 470J-T	T
C29	4030007090	S.CERAMIC C1608 CH 1H 470J-T	T
C30	4550006250	S.TANTALUM TEMSVA 1A 106M-8L	B
C31	4030008860	S.CERAMIC C1608 JB 1H 153K-T	T
C32	4030007160	S.CERAMIC C1608 CH 1H 181J-T	B
C33	4030007090	S.CERAMIC C1608 CH 1H 470J-T	T
C34	4030011810	S.CERAMIC C1608 JB 1A 224K-T	T
C35	4030006850	S.CERAMIC C1608 JB 1H 471K-T	T
C36	4030011810	S.CERAMIC C1608 JB 1A 224K-T	T
C37	4030006850	S.CERAMIC C1608 JB 1H 471K-T	T
C38	4030008880	S.CERAMIC C1608 JB 1H 223K-T	T
C39	4030006900	S.CERAMIC C1608 JB 1H 103K-T	B
C40	4030006860	S.CERAMIC C1608 JB 1H 102K-T	B
C41	4030007040	S.CERAMIC C1608 CH 1H 180J-T	B
C42	4030009970	S.CERAMIC C1608 JB 1H 182K-T	T
C43	4030011600	S.CERAMIC C1608 JB 1E 104K-T	T
C44	4030010770	S.CERAMIC C1608 JB 1H 392K-T	B
C45	4030008900	S.CERAMIC C1608 JB 1H 333K-T	T
C46	4030006860	S.CERAMIC C1608 JB 1H 102K-T	T
C47	4510007310	S.ELECTROLYTIC 16 CV 10 BS	T
C48	4030006940	S.CERAMIC C1608 CH 1H 030C-T	B
C49	4030008900	S.CERAMIC C1608 JB 1H 333K-T	T
C50	4030007030	S.CERAMIC C1608 CH 1H 150J-T	T
C51	4030009880	S.CERAMIC C1608 JB 1H 682K-T	B
C52	4030006900	S.CERAMIC C1608 JB 1H 103K-T	T
C53	4030006860	S.CERAMIC C1608 JB 1H 102K-T	T

M.=Mounted side (T: Mounted on the Top side, B: Mounted on the Bottom side)

[MAIN UNIT]

REF NO.	ORDER NO.	DESCRIPTION	M.
C54	4030011600	S.CERAMIC C1608 JB 1E 104K-T	B
C55	4030007020	S.CERAMIC C1608 CH 1H 120J-T	B
C56	4030006940	S.CERAMIC C1608 CH 1H 030C-T	B
C57	4030008860	S.CERAMIC C1608 JB 1H 153K-T	T
C58	4030009510	S.CERAMIC C1608 CH 1H 010B-T	B
C59	4030011330	S.CERAMIC C1608 CH 1H 391J-T	B
C60	4030011600	S.CERAMIC C1608 JB 1E 104K-T	B
C61	4030006900	S.CERAMIC C1608 JB 1H 103K-T	T
C63	4510007310	S.ELECTROLYTIC 16 CV 10 BS	T
C64	4030008900	S.CERAMIC C1608 JB 1H 333K-T	B
C66	4030006900	S.CERAMIC C1608 JB 1H 103K-T	B
C67	4030008920	S.CERAMIC C1608 JB 1H 473K-T	T
C68	4030008920	S.CERAMIC C1608 JB 1H 473K-T	T
C69	4030006860	S.CERAMIC C1608 JB 1H 102K-T	T
C70	4030007130	S.CERAMIC C1608 CH 1H 101J-T	B
C71	4030006850	S.CERAMIC C1608 JB 1H 471K-T	B
C72	4550003220	S.TANTALUM TEMSVA 1E 105M-8L	B
C73	4550000550	S.TANTALUM TESVA 1V 224M1-8L	T
C74	4550000550	S.TANTALUM TESVA 1V 224M1-8L	T
C76	4550006250	S.TANTALUM TEMSVA 1A 106M-8L	B
C77	4030011600	S.CERAMIC C1608 JB 1E 104K-T	B
C78	4030006860	S.CERAMIC C1608 JB 1H 102K-T	B
C79	4030011600	S.CERAMIC C1608 JB 1E 104K-T	T
C80	4030006860	S.CERAMIC C1608 JB 1H 102K-T	T
C81	4510008120	S.ELECTROLYTIC 16 CV 100 BS	T
C82	4030007170	S.CERAMIC C1608 CH 1H 221J-T	B
C83	4030007170	S.CERAMIC C1608 CH 1H 221J-T	T
C84	4550002980	S.TANTALUM TEMSVA 1C 225M-8L	T
C85	4550006250	S.TANTALUM TEMSVA 1A 106M-8L	T
C86	4550006480	S.TANTALUM TEMSVA 1C 475M-8L	B
C87	4030006860	S.CERAMIC C1608 JB 1H 102K-T	B
C90	4030007010	S.CERAMIC C1608 CH 1H 100D-T	B
C91	4030006860	S.CERAMIC C1608 JB 1H 102K-T	B
C92	4030006900	S.CERAMIC C1608 JB 1H 103K-T	B
C93	4030006860	S.CERAMIC C1608 JB 1H 102K-T	T
C94	4030006860	S.CERAMIC C1608 JB 1H 102K-T	B
C95	4030011600	S.CERAMIC C1608 JB 1E 104K-T	B
C96	4030017480	S.CERAMIC C1608 JB 1A 474K-T	B
C97	4030006860	S.CERAMIC C1608 JB 1H 102K-T	T
C98	4030007120	S.CERAMIC C1608 CH 1H 820J-T	B
C99	4030011600	S.CERAMIC C1608 JB 1E 104K-T	T
C100	4030008900	S.CERAMIC C1608 JB 1H 333K-T	B
C101	4030006860	S.CERAMIC C1608 JB 1H 102K-T	B
C102	4030006860	S.CERAMIC C1608 JB 1H 102K-T	B
C103	4030006900	S.CERAMIC C1608 JB 1H 103K-T	B
C104	4030008920	S.CERAMIC C1608 JB 1H 473K-T	B
C105	4030006860	S.CERAMIC C1608 JB 1H 102K-T	B
C106	4030006860	S.CERAMIC C1608 JB 1H 102K-T	T
C107	4030006860	S.CERAMIC C1608 JB 1H 102K-T	B
C108	4030006860	S.CERAMIC C1608 JB 1H 102K-T	B
C109	4550006050	S.TANTALUM TEMSVA 0J 106M8L	B
C110	4030011600	S.CERAMIC C1608 JB 1E 104K-T	T
C111	4030006900	S.CERAMIC C1608 JB 1H 103K-T	B
C112	4030011600	S.CERAMIC C1608 JB 1E 104K-T	B
C114	4030007000	S.CERAMIC C1608 CH 1H 090D-T	T
C115	4030006900	S.CERAMIC C1608 JB 1H 103K-T	T
C117	4030011600	S.CERAMIC C1608 JB 1E 104K-T	T
C118	4030006860	S.CERAMIC C1608 JB 1H 102K-T	B
C119	4030007030	S.CERAMIC C1608 CH 1H 150J-T	T
C120	4030006860	S.CERAMIC C1608 JB 1H 102K-T	B
C121	4030011600	S.CERAMIC C1608 JB 1E 104K-T	T
C122	4030007010	S.CERAMIC C1608 CH 1H 100D-T	T
C123	4030006860	S.CERAMIC C1608 JB 1H 102K-T	B
C124	4030006860	S.CERAMIC C1608 JB 1H 102K-T	T
C125	4030006860	S.CERAMIC C1608 JB 1H 102K-T	B
C126	4030006860	S.CERAMIC C1608 JB 1H 102K-T	B
C127	4030009520	S.CERAMIC C1608 CH 1H 020B-T	T
C128	4030006860	S.CERAMIC C1608 JB 1H 102K-T	T
C129	4030007010	S.CERAMIC C1608 CH 1H 100D-T	T
C130	4030007010	S.CERAMIC C1608 CH 1H 100D-T	B
C131	4030006940	S.CERAMIC C1608 CH 1H 030C-T	T
C132	4030006860	S.CERAMIC C1608 JB 1H 102K-T	T
C133	4030006860	S.CERAMIC C1608 JB 1H 102K-T	T
C134	4030006860	S.CERAMIC C1608 JB 1H 102K-T	B
C135	4030006860	S.CERAMIC C1608 JB 1H 102K-T	T
C136	4030006940	S.CERAMIC C1608 CH 1H 030C-T	T
C137	4030006860	S.CERAMIC C1608 JB 1H 102K-T	T
C138	4030011600	S.CERAMIC C1608 JB 1E 104K-T	T
C140	4030009520	S.CERAMIC C1608 CH 1H 020B-T	T
C141	4030007040	S.CERAMIC C1608 CH 1H 180J-T	T
C142	4030006860	S.CERAMIC C1608 JB 1H 102K-T	T

S.=Surface mount

**[MAIN UNIT]**

REF NO.	ORDER NO.	DESCRIPTION		M.
C143	4030006860	S.CERAMIC	C1608 JB 1H 102K-T	B
C144	4030006860	S.CERAMIC	C1608 JB 1H 102K-T	T
C145	4030007090	S.CERAMIC	C1608 CH 1H 470J-T	T
C146	4030006860	S.CERAMIC	C1608 JB 1H 102K-T	T
C147	4030006860	S.CERAMIC	C1608 JB 1H 102K-T	B
C148	4030009560	S.CERAMIC	C1608 CH 1H R75B-T	T
C149	4030006900	S.CERAMIC	C1608 JB 1H 103K-T	T
C150	4030007050	S.CERAMIC	C1608 CH 1H 220J-T	B
C151	4030006980	S.CERAMIC	C1608 CH 1H 070D-T	T
C152	4030006860	S.CERAMIC	C1608 JB 1H 102K-T	B
C154	4030009520	S.CERAMIC	C1608 CH 1H 020B-T	T
C155	4030006990	S.CERAMIC	C1608 CH 1H 080D-T	T
C157	4030006860	S.CERAMIC	C1608 JB 1H 102K-T	B
C159	4030006860	S.CERAMIC	C1608 JB 1H 102K-T	B
C161	4030006860	S.CERAMIC	C1608 JB 1H 102K-T	T
C162	4030009520	S.CERAMIC	C1608 CH 1H 020B-T	T
C163	4030009520	S.CERAMIC	C1608 CH 1H 020B-T	T
C164	4030007040	S.CERAMIC	C1608 CH 1H 180J-T	B
C165	4030006860	S.CERAMIC	C1608 JB 1H 102K-T	B
C166	4030007010	S.CERAMIC	C1608 CH 1H 100D-T	T
C167	4030006860	S.CERAMIC	C1608 JB 1H 102K-T	T
C168	4030007090	S.CERAMIC	C1608 CH 1H 470J-T	B
C169	4030006860	S.CERAMIC	C1608 JB 1H 102K-T	T
C170	4030007130	S.CERAMIC	C1608 CH 1H 101J-T	T
C171	4030006860	S.CERAMIC	C1608 JB 1H 102K-T	T
C172	4030006860	S.CERAMIC	C1608 JB 1H 102K-T	B
C173	4030006860	S.CERAMIC	C1608 JB 1H 102K-T	T
C174	4030007130	S.CERAMIC	C1608 CH 1H 101J-T	T
C175	4030006860	S.CERAMIC	C1608 JB 1H 102K-T	T
C176	4030009520	S.CERAMIC	C1608 CH 1H 020B-T	T
C177	4030006860	S.CERAMIC	C1608 JB 1H 102K-T	T
C178	4030009510	S.CERAMIC	C1608 CH 1H 010B-T	B
C179	4030006860	S.CERAMIC	C1608 JB 1H 102K-T	T
C180	4030007130	S.CERAMIC	C1608 CH 1H 101J-T	T
C181	4030006920	S.CERAMIC	C1608 CH 1H 010C-T	T
C182	4030009910	S.CERAMIC	C1608 CH 1H 040B-T	T
C183	4030011160	S.CERAMIC	GRM31M2C2H150JV01L (GRM42-6 CH)	T
C185	4030007120	S.CERAMIC	C1608 CH 1H 820J-T	T
C186	4030006860	S.CERAMIC	C1608 JB 1H 102K-T	T
C187	4030009520	S.CERAMIC	C1608 CH 1H 020B-T	T
C188	4030006950	S.CERAMIC	C1608 CH 1H 040C-T	T
C189	4030011210	S.CERAMIC	GRM31M2C2H330JV01L (GRM42-6 CH)	T
C190	4030011060	S.CERAMIC	GRM31M2C2H4R0CY21L (GRM42-6 CH)	T
C191	4030009530	S.CERAMIC	C1608 CH 1H 030B-T	T
C192	4030011020	S.CERAMIC	GRM31M4C2H1R0CY21L (GRM42-6 CK)	B
C193	4030011140	S.CERAMIC	GRM31M2C2H120JV01L (GRM42-6 CH)	B
C194	4030011020	S.CERAMIC	GRM31M4C2H1R0CY21L (GRM42-6 CK)	T
C195	4030011150	S.CERAMIC	GRM31M2C2H130JV01L (GRM42-6 CH)	T
C196	4030007170	S.CERAMIC	C1608 CH 1H 221J-T	T
C197	4030007020	S.CERAMIC	C1608 CH 1H 120J-T	T
C198	4030006920	S.CERAMIC	C1608 CH 1H 010C-T	T
C199	4030006860	S.CERAMIC	C1608 JB 1H 102K-T	B
C200	4030006860	S.CERAMIC	C1608 JB 1H 102K-T	T
C201	4030006860	S.CERAMIC	C1608 JB 1H 102K-T	T
C202	4030006860	S.CERAMIC	C1608 JB 1H 102K-T	T
C203	4030006860	S.CERAMIC	C1608 JB 1H 102K-T	T
C204	4030009520	S.CERAMIC	C1608 CH 1H 020B-T	T
C205	4030010780	S.CERAMIC	C1608 CH 1H 1R5C-T	T
C206	4030009510	S.CERAMIC	C1608 CH 1H 010B-T	T
C208	4030007140	S.CERAMIC	C1608 CH 1H 121J-T	T
C209	4030006860	S.CERAMIC	C1608 JB 1H 102K-T	T
C210	4030006860	S.CERAMIC	C1608 JB 1H 102K-T	T
C211	4030006860	S.CERAMIC	C1608 JB 1H 102K-T	T
C212	4030011280	S.CERAMIC	C1608 CH 1H 271J-T	T
C213	4030007020	S.CERAMIC	C1608 CH 1H 120J-T	T
C214	4030006860	S.CERAMIC	C1608 JB 1H 102K-T	T
C215	4030009540	S.CERAMIC	C1608 CH 1H 1R5B-T	T
C216	4030006860	S.CERAMIC	C1608 JB 1H 102K-T	B
C217	4030006860	S.CERAMIC	C1608 JB 1H 102K-T	B
C218	4030006940	S.CERAMIC	C1608 CH 1H 030C-T	T
C219	4030006860	S.CERAMIC	C1608 JB 1H 102K-T	T
C221	4030006860	S.CERAMIC	C1608 JB 1H 102K-T	T
C222	4030006860	S.CERAMIC	C1608 JB 1H 102K-T	T
C223	4030007130	S.CERAMIC	C1608 CH 1H 101J-T	T
C224	4030006900	S.CERAMIC	C1608 JB 1H 103K-T	T
C225	4030006900	S.CERAMIC	C1608 JB 1H 103K-T	T
C226	4030006900	S.CERAMIC	C1608 JB 1H 103K-T	T
C227	4030006860	S.CERAMIC	C1608 JB 1H 102K-T	T
C230	4030011020	S.CERAMIC	GRM31M4C2H1R0CY21L (GRM42-6 CK)	B
C231	4030011120	S.CERAMIC	GRM31M2C2H100JV01L (GRM42-6 CH)	B
C232	4030011020	S.CERAMIC	GRM31M4C2H1R0CY21L (GRM42-6 CK)	B

M.=Mounted side (T: Mounted on the Top side, B: Mounted on the Bottom side)

**[MAIN UNIT]**

REF NO.	ORDER NO.	DESCRIPTION		M.
C233	4030011140	S.CERAMIC	GRM31M2C2H120JV01L (GRM42-6 CH)	B
C234	4030006860	S.CERAMIC	C1608 JB 1H 102K-T	B
C235	4030006860	S.CERAMIC	C1608 JB 1H 102K-T	T
C236	4030006860	S.CERAMIC	C1608 JB 1H 102K-T	T
C237	4030008920	S.CERAMIC	C1608 JB 1H 473K-T	T
C238	4030006860	S.CERAMIC	C1608 JB 1H 102K-T	T
C240	4030006860	S.CERAMIC	C1608 JB 1H 102K-T	B
C241	4030006860	S.CERAMIC	C1608 JB 1H 102K-T	B
C242	4030007050	S.CERAMIC	C1608 CH 1H 220J-T	T
C243	4030009920	S.CERAMIC	C1608 CH 1H 050B-T	T
C244	4030006860	S.CERAMIC	C1608 JB 1H 102K-T	T
C245	4030006860	S.CERAMIC	C1608 JB 1H 102K-T	T
C246	4030017190	S.CERAMIC	GRM31AR32J471KW01D	T
C247	4030009920	S.CERAMIC	C1608 CH 1H 050B-T	T
C248	4030007040	S.CERAMIC	C1608 CH 1H 180J-T	T
C249	4510008110	S.ELECTROLYTIC	16 CV 22 BS	T
C250	4030006860	S.CERAMIC	C2012 JF 1C 105Z-T	T
C251	4030006860	S.CERAMIC	C1608 JB 1H 102K-T	T
C252	4030006900	S.CERAMIC	C1608 JB 1H 103K-T	T
C253	4030007170	S.CERAMIC	C1608 CH 1H 221J-T	T
C254	4030007020	S.CERAMIC	C1608 CH 1H 120J-T	T
C255	4030006860	S.CERAMIC	C1608 JB 1H 102K-T	B
C256	4030006860	S.CERAMIC	C1608 JB 1H 102K-T	B
C257	4030006860	S.CERAMIC	C1608 JB 1H 102K-T	B
C258	4030006860	S.CERAMIC	C1608 JB 1H 102K-T	B
C259	4030017200	S.CERAMIC	GRM31BR32J102KY01L (GHM1030 R)	B
C260	4030009910	S.CERAMIC	C1608 CH 1H 040B-T	T
C261	4030007010	S.CERAMIC	C1608 CH 1H 100D-T	T
C262	4030006860	S.CERAMIC	C1608 JB 1H 102K-T	T
C263	4030006860	S.CERAMIC	C1608 JB 1H 102K-T	T
C264	4030006860	S.CERAMIC	C1608 JB 1H 102K-T	B
C266	4030006860	S.CERAMIC	C1608 JB 1H 102K-T	T
C267	4030006900	S.CERAMIC	C1608 JB 1H 103K-T	T
C268	4030006860	S.CERAMIC	C1608 JB 1H 102K-T	T
C269	4030007130	S.CERAMIC	C1608 CH 1H 101J-T	T
C270	4510008110	S.ELECTROLYTIC	16 CV 22 BS	T
C271	4030011160	S.CERAMIC	GRM31M2C2H150JV01L (GRM42-6 CH)	B
C272	4030011600	S.CERAMIC	C1608 JB 1E 104K-T	B
C273	4030007170	S.CERAMIC	C1608 CH 1H 221J-T	T
C274	4030006900	S.CERAMIC	C1608 JB 1H 103K-T	B
C276	4030006860	S.CERAMIC	C1608 JB 1H 102K-T	T
C277	4030006860	S.CERAMIC	C1608 JB 1H 102K-T	T
C278	4030006860	S.CERAMIC	C1608 JB 1H 102K-T	B
C279	4030017200	S.CERAMIC	GRM31BR32J102KY01L (GHM1030 R)	T
C280	4030006970	S.CERAMIC	C1608 CH 1H 060D-T	T
C281	4030006860	S.CERAMIC	C1608 JB 1H 102K-T	T
C282	4030011170	S.CERAMIC	GRM31M2C2H180JV01L (GRM42-6 CH)	T
C283	4030011600	S.CERAMIC	C1608 JB 1E 104K-T	B
C284	4030011140	S.CERAMIC	GRM31M2C2H120JV01L (GRM42-6 CH)	T
C285	4030011220	S.CERAMIC	GRM31M2C2H360JV01L (GRM42-6 CH)	T
C286	4030006860	S.CERAMIC	C1608 JB 1H 102K-T	B
C288	4030011090	S.CERAMIC	GRM31M2C2H7R0DV01L (GRM42-6 CH)	T
C289	4030011190	S.CERAMIC	GRM31M2C2H270JV01L (GRM42-6 CH)	T
C290	4030009500	S.CERAMIC	C1608 CH 1H 0R5B-T	T
C291	4030006860	S.CERAMIC	C1608 JB 1H 102K-T	T
C292	4030011110	S.CERAMIC	GRM31M2C2H9R0DV01L (GRM42-6 CH)	T
C293	4030006860	S.CERAMIC	C1608 JB 1H 102K-T	T
C294	4030006860	S.CERAMIC	C1608 JB 1H 102K-T	T
C295	4030011070	S.CERAMIC	GRM31M2C2H5R0CY21L (GRM42-6 CH)	T
C296	4030006940	S.CERAMIC	C1608 CH 1H 030C-T	T
C297	4030008920	S.CERAMIC	C1608 JB 1H 473K-T	T
C298	4030009540	S.CERAMIC	C1608 CH 1H 1R5B-T	B
C299	4030011090	S.CERAMIC	GRM31M2C2H270JV01L (GRM42-6 CH)	T
C300	4030006860	S.CERAMIC	C1608 JB 1H 102K-T	T
C301	4030009920	S.CERAMIC	C1608 CH 1H 050B-T	B
C302	4030009560	S.CERAMIC	C1608 CH 1H R75B-T	B
C303	4030007060	S.CERAMIC	C1608 CH 1H 270J-T	B
C304	4030009540	S.CERAMIC	C1608 CH 1H 1R5B-T	B
C305	4030011170	S.CERAMIC	GRM31M2C2H180JV01L (GRM42-6 CH)	B
C306	4030011040	S.CERAMIC	GRM31M4C2H2R0CY21L (GRM42-6 CK)	B
C501	4030011600	S.CERAMIC	C1608 JB 1E 104K-T	T
C502	4510006020	ELECTROLYTIC	16 MV 2200 HC	T
C503	4030006860	S.CERAMIC	C1608 JB 1H 102K-T	T
C504	4030009590	S.CERAMIC	C2012 JF 1C 225Z-T	B
C505	4030006900	S.CERAMIC	C1608 JB 1H 103K-T	B
C506	4030007090	S.CERAMIC	C1608 CH 1H 470J-T	B
C507	4030012610	S.CERAMIC	C2012 JB 1C 474K-T	B
C508	4030006900	S.CERAMIC	C1608 JB 1H 103K-T	B
C509	4030007090	S.CERAMIC	C1608 CH 1H 470J-T	B
C510	4030006860	S.CERAMIC	C1608 JB 1H 102K-T	B
C511	4030007070	S.CERAMIC	C1608 CH 1H 330J-T	B

S.=Surface mount

[MAIN UNIT]

REF NO.	ORDER NO.	DESCRIPTION	M.
C512	4030006860	S.CERAMIC C1608 JB 1H 102K-T	T
C513	4030011600	S.CERAMIC C1608 JB 1E 104K-T	T
C514	4030009910	S.CERAMIC C1608 CH 1H 040B-T	B
C515	4030006860	S.CERAMIC C1608 JB 1H 102K-T	B
C516	4030006860	S.CERAMIC C1608 JB 1H 102K-T	T
C517	4030007090	S.CERAMIC C1608 CH 1H 470J-T	T
C519	4030008900	S.CERAMIC C1608 JB 1H 333K-T	B
C520	4030007050	S.CERAMIC C1608 CH 1H 220J-T	B
C521	4030011600	S.CERAMIC C1608 JB 1E 104K-T	B
C522	4030006860	S.CERAMIC C1608 JB 1H 102K-T	B
C523	4030006860	S.CERAMIC C1608 JB 1H 102K-T	T
C524	4030007090	S.CERAMIC C1608 CH 1H 470J-T	B
C525	4550006210	S.TANTALUM ECST1CX106R	T
C526	4030006860	S.CERAMIC C1608 JB 1H 102K-T	B
C527	4030012610	S.CERAMIC C2012 JB 1C 474K-T	B
C528	4030007090	S.CERAMIC C1608 CH 1H 470J-T	B
C529	4510007310	S.ELECTROLYTIC 16 CV 10 BS	T
C531	4550006210	S.TANTALUM ECST1CX106R	T
C532	4550006210	S.TANTALUM ECST1CX106R	T
C533	4030008910	S.CERAMIC C1608 JB 1H 393K-T	T
C534	4030008910	S.CERAMIC C1608 JB 1H 393K-T	T
C535	4030011600	S.CERAMIC C1608 JB 1E 104K-T	T
C536	4030011600	S.CERAMIC C1608 JB 1E 104K-T	T
C537	4030012600	S.CERAMIC C2012 JB 1A 105M-T	T
C538	4510007280	S.ELECTROLYTIC 50 CV 2R2 BS	T
C539	4030006860	S.CERAMIC C1608 JB 1H 102K-T	T
C540	4030006860	S.CERAMIC C1608 JB 1H 102K-T	T
C542	4030011600	S.CERAMIC C1608 JB 1E 104K-T	B
C544	4030011600	S.CERAMIC C1608 JB 1E 104K-T	T
C545	4030006900	S.CERAMIC C1608 JB 1H 103K-T	B
C546	4550006760	S.TANTALUM TEMSVB2 1A 336M-8R	T
C547	4030008680	S.CERAMIC C2012 JF 1C 105Z-T	T
C548	4030008680	S.CERAMIC C1608 JB 1H 273K-T	T
C549	4510007310	S.ELECTROLYTIC 16 CV 10 BS	T
C550	4030006860	S.CERAMIC C1608 JB 1H 102K-T	T
C551	4030011600	S.CERAMIC C1608 JB 1E 104K-T	T
C552	4030006900	S.CERAMIC C1608 JB 1H 103K-T	T
C553	4030008680	S.CERAMIC C2012 JF 1C 105Z-T	T
C554	4030011600	S.CERAMIC C1608 JB 1E 104K-T	T
C555	4030008880	S.CERAMIC C1608 JB 1H 223K-T	T
C556	4030011600	S.CERAMIC C1608 JB 1E 104K-T	T
C557	4030008650	S.CERAMIC C1608 JB 1H 332K-T	T
C558	4030006860	S.CERAMIC C1608 JB 1H 102K-T	T
C559	4030008650	S.CERAMIC C1608 JB 1H 332K-T	T
C560	4030012610	S.CERAMIC C2012 JB 1C 474K-T	T
C561	4030006860	S.CERAMIC C1608 JB 1H 102K-T	T
C562	4030006860	S.CERAMIC C1608 JB 1H 102K-T	T
C563	4030008920	S.CERAMIC C1608 JB 1H 473K-T	T
C564	4030011810	S.CERAMIC C1608 JB 1A 224K-T	T
C566	4510007310	S.ELECTROLYTIC 16 CV 10 BS	T
C567	4510008130	S.ELECTROLYTIC 16 CV 220 BS	T
C568	4510008140	S.ELECTROLYTIC 10 CV 470 BS	T
C569	4030011600	S.CERAMIC C1608 JB 1E 104K-T	T
C570	4030011600	S.CERAMIC C1608 JB 1E 104K-T	T
C571	4030011600	S.CERAMIC C1608 JB 1E 104K-T	B
C572	4030007090	S.CERAMIC C1608 CH 1H 470J-T	B
C573	4030008680	S.CERAMIC C2012 JF 1C 105Z-T	T
C574	4510007310	S.ELECTROLYTIC 16 CV 10 BS	T
C575	4510007310	S.ELECTROLYTIC 16 CV 10 BS	T
C577	4550006170	S.TANTALUM ECST1AY225R	B
C579	4030006860	S.CERAMIC C1608 JB 1H 102K-T	T
C580	4030006860	S.CERAMIC C1608 JB 1H 102K-T	B
C581	4030006860	S.CERAMIC C1608 JB 1H 102K-T	T
C582	4550006170	S.TANTALUM ECST1AY225R	T
C584	4030006860	S.CERAMIC C1608 JB 1H 102K-T	T
C585	4030006860	S.CERAMIC C1608 JB 1H 102K-T	T
C586	4030011730	S.CERAMIC GRM31M2C2H101JV01L (GRM42-6 CH)	B
C587	4030011600	S.CERAMIC C1608 JB 1E 104K-T	T
C589	4030006860	S.CERAMIC C1608 JB 1H 102K-T	B
C590	4030006860	S.CERAMIC C1608 JB 1H 102K-T	B
C591	4030006860	S.CERAMIC C1608 JB 1H 102K-T	B
C592	4030006860	S.CERAMIC C1608 JB 1H 102K-T	B
C593	4030006860	S.CERAMIC C1608 JB 1H 102K-T	T
C594	4030006860	S.CERAMIC C1608 JB 1H 102K-T	T
C595	4030006860	S.CERAMIC C1608 JB 1H 102K-T	T
C596	4030006860	S.CERAMIC C1608 JB 1H 102K-T	T
C597	4030007060	S.CERAMIC C1608 CH 1H 270J-T	T
C598	4030006860	S.CERAMIC C1608 JB 1H 102K-T	T
C599	4030006950	S.CERAMIC C1608 CH 1H 040C-T	T
C600	4030006860	S.CERAMIC C1608 JB 1H 102K-T	T
C601	4030006860	S.CERAMIC C1608 JB 1H 102K-T	T

M.=Mounted side (T: Mounted on the Top side, B: Mounted on the Bottom side)

[MAIN UNIT]

REF NO.	ORDER NO.	DESCRIPTION	M.
C602	4030006860	S.CERAMIC C1608 JB 1H 102K-T	T
C603	4030006860	S.CERAMIC C1608 JB 1H 102K-T	B
C604	4030006860	S.CERAMIC C1608 JB 1H 102K-T	B
C605	4030006860	S.CERAMIC C1608 JB 1H 102K-T	B
C606	4030007130	S.CERAMIC C1608 CH 1H 101J-T	T
C607	4030007130	S.CERAMIC C1608 CH 1H 101J-T	T
C608	4030006860	S.CERAMIC C1608 JB 1H 102K-T	B
C609	4030006860	S.CERAMIC C1608 JB 1H 102K-T	B
C610	4030006980	S.CERAMIC C1608 CH 1H 070D-T	B
C611	4030006860	S.CERAMIC C1608 JB 1H 102K-T	B
C612	4030006900	S.CERAMIC C1608 JB 1H 103K-T	B
C616	4030007090	S.CERAMIC C1608 CH 1H 470J-T	B
C617	4030007090	S.CERAMIC C1608 CH 1H 470J-T	B
C618	4030007090	S.CERAMIC C1608 CH 1H 470J-T	B
C619	4030007090	S.CERAMIC C1608 CH 1H 470J-T	B
C620	4030006860	S.CERAMIC C1608 JB 1H 102K-T	B
C621	4030006860	S.CERAMIC C1608 JB 1H 102K-T	B
C623	4030006860	S.CERAMIC C1608 JB 1H 102K-T	B
C624	4030006860	S.CERAMIC C1608 JB 1H 102K-T	B
C625	4030006860	S.CERAMIC C1608 JB 1H 102K-T	B
C626	4030006860	S.CERAMIC C1608 JB 1H 102K-T	B
C627	4030006860	S.CERAMIC C1608 JB 1H 102K-T	B
C628	4030006860	S.CERAMIC C1608 JB 1H 102K-T	B
C629	4030006860	S.CERAMIC C1608 JB 1H 102K-T	B
C630	4030006860	S.CERAMIC C1608 JB 1H 102K-T	B
C632	4030007090	S.CERAMIC C1608 CH 1H 470J-T	T
C633	4030007140	S.CERAMIC C1608 CH 1H 121J-T	B
C634	4030007140	S.CERAMIC C1608 CH 1H 121J-T	B
C635	4030006860	S.CERAMIC C1608 JB 1H 102K-T	B
C636	4030011810	S.CERAMIC C1608 JB 1A 224K-T	B
C637	4030011810	S.CERAMIC C1608 JB 1A 224K-T	B
C638	4030006860	S.CERAMIC C1608 JB 1H 102K-T	T
C639	4030006860	S.CERAMIC C1608 JB 1H 102K-T	B
C640	4030006860	S.CERAMIC C1608 JB 1H 102K-T	T
C641	4030006860	S.CERAMIC C1608 JB 1H 102K-T	T
C642	4030006860	S.CERAMIC C1608 JB 1H 102K-T	T
C643	4030006860	S.CERAMIC C1608 JB 1H 102K-T	T
C644	4030011810	S.CERAMIC C1608 JB 1A 224K-T	B
C645	4030011810	S.CERAMIC C1608 JB 1A 224K-T	B
C646	4030006860	S.CERAMIC C1608 JB 1H 102K-T	B
C647	4030006860	S.CERAMIC C1608 JB 1H 102K-T	B
C648	4030006860	S.CERAMIC C1608 JB 1H 102K-T	B
C649	4030006860	S.CERAMIC C1608 JB 1H 102K-T	B
C650	4030006860	S.CERAMIC C1608 JB 1H 102K-T	B
C651	4030006860	S.CERAMIC C1608 JB 1H 102K-T	B
C652	4030006860	S.CERAMIC C1608 JB 1H 102K-T	B
C654	4030007090	S.CERAMIC C1608 CH 1H 470J-T	T
C655	4030007090	S.CERAMIC C1608 CH 1H 470J-T	T
C656	4030006860	S.CERAMIC C1608 JB 1H 102K-T	T
C657	4030006860	S.CERAMIC C1608 JB 1H 102K-T	T
C658	4030006860	S.CERAMIC C1608 JB 1H 102K-T	[USA] only
C659	4030006860	S.CERAMIC C1608 JB 1H 102K-T	T
C660	4030006860	S.CERAMIC C1608 JB 1H 102K-T	T
C661	4030006860	S.CERAMIC C1608 JB 1H 102K-T	T
C662	4030006860	S.CERAMIC C1608 JB 1H 102K-T	B
C663	4030006860	S.CERAMIC C1608 JB 1H 102K-T	B
C664	4030006860	S.CERAMIC C1608 JB 1H 102K-T	T
C665	4030006860	S.CERAMIC C1608 JB 1H 102K-T	T
C666	4030007010	S.CERAMIC C1608 CH 1H 100D-T	B
C667	4030007010	S.CERAMIC C1608 CH 1H 100D-T	B
C668	4030007010	S.CERAMIC C1608 CH 1H 100D-T	B
C669	4030007010	S.CERAMIC C1608 CH 1H 100D-T	B
C670	4030006860	S.CERAMIC C1608 JB 1H 102K-T	T
J1	6510014960	S.CONNECTOR B2B-ZR-SM3-TF	T
J502	6510023110	CONNECTOR 3008L-8P8C <KIN>	T
J503	6510019321	CONNECTOR 1729 REAR CONNECTOR-1	T
J504	6510023160	CONNECTOR DN-508B-6 <KUO>	T
J505	6510014960	S.CONNECTOR B2B-ZR-SM3-TF	T
J506	6510023590	CONNECTOR HSJ2000-01-010	T
W1	7120000470	JUMPER ERDS2T0	T
W2	7120000470	JUMPER ERDS2T0	T
W3	7120000470	JUMPER ERDS2T0	T
W501	8900004880	CABLE OPC-465	T
W502	7030003860	S.JUMPER ERJ3GE JPW V	B
W503	7030003860	S.JUMPER ERJ3GE JPW V	B
W504	7030003860	S.JUMPER ERJ3GE JPW V	T
W505	7030000010	S.JUMPER MCR10EZHJ JPW (000)	T

S.=Surface mount

[MAIN UNIT]

REF NO.	ORDER NO.		DESCRIPTION	M.
W506	7030000010	S.JUMPER	MCR10EZHJ JPW (000)	T
W507	7030003860	S.JUMPER	ERJ3GE JPW V	T
W508	7030003860	S.JUMPER	ERJ3GE JPW V	T
W509	7030000010	S.JUMPER	MCR10EZHJ JPW (000)	T
W510	7030003860	S.JUMPER	ERJ3GE JPW V	T
W511	7030003860	S.JUMPER	ERJ3GE JPW V	B
W512	7030003860	S.JUMPER	ERJ3GE JPW V	B
W513	7030003860	S.JUMPER	ERJ3GE JPW V	B
W514	7030003860	S.JUMPER	ERJ3GE JPW V	T
W515	7030000010	S.JUMPER	MCR10EZHJ JPW (000)	T
W518	7030000010	S.JUMPER	MCR10EZHJ JPW (000)	B
W519	7030000010	S.JUMPER	MCR10EZHJ JPW (000)	B
W520	7030003860	S.JUMPER	ERJ3GE JPW V	B
W521	7030003860	S.JUMPER	ERJ3GE JPW V	T
W522	7030003860	S.JUMPER	ERJ3GE JPW V	T
W523	7030003860	S.JUMPER	ERJ3GE JPW V	T
W524	7030003860	S.JUMPER	ERJ3GE JPW V	T
W525	7030003860	S.JUMPER	ERJ3GE JPW V	T
W526	7030003860	S.JUMPER	ERJ3GE JPW V	T
W527	7030003860	S.JUMPER	ERJ3GE JPW V	T
W528	7030003860	S.JUMPER	ERJ3GE JPW V	B
W529	7030003860	S.JUMPER	ERJ3GE JPW V	B
W530	7030003860	S.JUMPER	ERJ3GE JPW V	B
W531	7030003860	S.JUMPER	ERJ3GE JPW V	B
W532	7030003860	S.JUMPER	ERJ3GE JPW V	B
W533	7030003860	S.JUMPER	ERJ3GE JPW V	B
W534	7030003860	S.JUMPER	ERJ3GE JPW V	B
W535	7030003860	S.JUMPER	ERJ3GE JPW V	B
W536	7030003860	S.JUMPER	ERJ3GE JPW V	B
W537	7030003860	S.JUMPER	ERJ3GE JPW V	B
W538	7030003860	S.JUMPER	ERJ3GE JPW V	B
W539	7030003860	S.JUMPER	ERJ3GE JPW V	B
W540	7030003860	S.JUMPER	ERJ3GE JPW V	B
W541	7030003860	S.JUMPER	ERJ3GE JPW V	B
W542	7030003860	S.JUMPER	ERJ3GE JPW V	B
W543	7030003860	S.JUMPER	ERJ3GE JPW V	B
W544	7030003860	S.JUMPER	ERJ3GE JPW V	T
W545	7030000010	S.JUMPER	MCR10EZHJ JPW (000)	T
W546	7030000010	S.JUMPER	MCR10EZHJ JPW (000)	T
W548	7030003860	S.JUMPER	ERJ3GE JPW V	B
EP1	6910012350	S.BEAD	MMZ1608Y 102BT	T
EP2	6910012350	S.BEAD	MMZ1608Y 102BT	T
EP10	6910000660	BEAD	FSRH082149RL000B (FSOH082RL)	T
EP11	6910000660	BEAD	FSRH082149RL000B (FSOH082RL)	T
EP501	6910012350	S.BEAD	MMZ1608Y 102BT	B
EP502	6910012350	S.BEAD	MMZ1608Y 102BT	B
EP503	6910012350	S.BEAD	MMZ1608Y 102BT	T
EP504	6910012350	S.BEAD	MMZ1608Y 102BT	T
EP505	6910012350	S.BEAD	MMZ1608Y 102BT	B
EP506	6910012350	S.BEAD	MMZ1608Y 102BT	B
EP507	6910012350	S.BEAD	MMZ1608Y 102BT	B
EP508	6910012350	S.BEAD	MMZ1608Y 102BT	B
EP509	6910015120	S.BEAD	MMZ2012D 301BT	B
EP510	6910015130	S.BEAD	MMZ1608D 301BT	B
EP511	6910015120	S.BEAD	MMZ2012D 301BT	T
EP512	6910012350	S.BEAD	MMZ1608Y 102BT	T
EP513	6910012350	S.BEAD	MMZ1608Y 102BT	T
EP514	6910012350	S.BEAD	MMZ1608Y 102BT	B
EP515	6910012350	S.BEAD	MMZ1608Y 102BT	B
EP517	6910012350	S.BEAD	MMZ1608Y 102BT	T
EP518	6910012350	S.BEAD	MMZ1608Y 102BT	T
EP519	6910012350	S.BEAD	MMZ1608Y 102BT	B
EP520	6910012350	S.BEAD	MMZ1608Y 102BT	B
EP521	6910012350	S.BEAD	MMZ1608Y 102BT	B
EP522	6910012350	S.BEAD	MMZ1608Y 102BT	B
EP523	6910012350	S.BEAD	MMZ1608Y 102BT	B
EP524	6910012350	S.BEAD	MMZ1608Y 102BT	T
EP525	6910012350	S.BEAD	MMZ1608Y 102BT	B
EP526	6910012350	S.BEAD	MMZ1608Y 102BT	T
EP527	0910056483	PCB	B 5946C	B
EP528	6910012350	S.BEAD	MMZ1608Y 102BT	B

M.=Mounted side (T: Mounted on the Top side, B: Mounted on the Bottom side)

S.=Surface mount

# SECTION 7 MECHANICAL PARTS AND DISASSEMBLY

## [CHASSIS PART]

REF. NO.	ORDER NO.	DESCRIPTION	QTY.
J1	6510004880	Connector MR-DS-E 01	1
SP1	2510001160	Speaker 057P0802	1
MF1	2710000760	Fan FD1240107B-1N	1
MP1	8010019240	2633 chassis	1
MP2	8930059790	2633 SP rubber	1
MP3	8930041552	1893 OPC plate-2	1
MP4	8930041560	1893 release button	1
MP5	8810008660	Screw PH BT M3 × 8 NI-ZU	1
MP6	8810008660	Screw PH BT M3 × 8 NI-ZU	2
MP7	8810008660	Screw PH BT M3 × 8 NI-ZU	4
MP8	8810008660	Screw PH BT M3 × 8 NI-ZU	6
MP9	8810009610	Screw FH M2.6 × 6 ZK	4
MP10	8110005751	1729 fan cover-1	1
MP11	8810009110	Screw PH M2.6 × 16 ZK	4
MP12	8810009560	Screw PH BT M2 × 6 ZK	3
MP13	8110007950	2633 cover	1
MP14	8930003170	60 saran net	1
MP17	8930041870	Spring (AC)	1
MP19	8930039610	Thermally sheet (C)	1
MP20	8930039610	Thermally sheet (C)	1
MP21	8930043010	1893 sheet	1
MP24	8510015370	2633 shield cover	1
MP26	8930060350	Thermally sheet (AK)	1
MP27	8930060350	Thermally sheet (AK)	1
WS1	8600036880	SP cable	1

## [MAIN UNIT]

REF. NO.	ORDER NO.	DESCRIPTION	QTY.
J502	6510023110	Connector 3008L-8P8C	1
J503	6510019321	1729 rear connector-1	1
J504	6510023160	Connector DN-508B-6	1
J506	6510023590	Connector HSJ2000-01-010	1
W501	8900004880	Cable OPC-465	1
EP10	6910000660	Bead FS0H082RL	1
EP11	6910000660	Bead FS0H082RL	1
MP1	8930059770	2633 M-holder	2
MP2	8510011290	1893 A-CPU plate	1
MP3	8510011300	1893 modular plate	1
MP4	8930059750	2633 H.V. plate	1
MP5	8930060270	2633 M-sheet	1
MP6	8510015470	2633 C-shield plate	1
	8510015410	2633 A-shield plate	1
MP7	8930060260	2633 spring	1
MP8	8510015460	2633 B-shield plate	1
MP9	8510015440	2633 connector plate	1
MP10	8930060260	2633 spring	1

## [VCO BOARD]

REF. NO.	ORDER NO.	DESCRIPTION	QTY.
MP1	8510015420	2633 shield case assembly	1
MP2	8510015270	2633 VCO case	1
MP3	8510015280	2633 VCO cover	1

## [ACCESSORIES]

REF. NO.	ORDER NO.	DESCRIPTION	QTY.
F1	5210000080	Fuse FGB 20A	1
MC1	0880000980	Microphone HM-133	1
W1	8900010990	Cable OPC-1132	1
W2	8900012250	Cable OPC-600R	1
	8900007490	Cable OPC-600	1
MP1	8010019260	2633 mobile bracket	1
MP3	8820000530	Flange bolt M4 × 8 NI	4
MP4	8810000470	Screw PH M5 × 12 (+-)	4
MP5	8810000950	Screw A M5 × 16	4
MP6	8850000150	Flat washer M5 NI BS	4
MP7	8850000390	Spring washer M5	4
MP8	8830000120	Nut M5	4
MP9	8930007300	Mic hanger	1

**Screw abbreviations** BT,B0: Self-tapping  
 PH: Pan head      FH: Flat head  
 ZK: Black          BS: Brass  
 NI: Nickel          NI-ZU: Nickel-Zinc

## [CONTROL UNIT]

REF. NO.	ORDER NO.	DESCRIPTION	QTY.
R1	7210002920	Variable resistor EVU-F2AF20B55	1
R5	7210002920	Variable resistor EVU-F2AF20B55	1
S1	2240000150	Switch JRS0000-1401	1
DS1	5030002580	LCD L2-0736TAY	1
DS22	5040002920	LED CV1074	1
EP18	8930060040	LCD contact SRCN-2633-SP-N-W	1
MP1	8210019850	2633 front panel (B)	1
MP2	8210019540	2633 rear panel	1
MP3	8610011290	Knob N297	1
MP4	8610011300	Knob N298	1
MP5	8610011280	Knob N299	1
MP6	8310057030	2633 key-top	1
MP7	8210019550	2633 D-reflector	1
MP8	8930059740	2633 power button	1
MP9	8930059730	2633 2-key	1
MP10	8610011310	Knob K299	1
MP11	8610011350	Knob K299 (A)	1
MP12	8610011340	Knob K299 (B)	1
MP13	8610011330	Knob K299 (C)	1
MP14	8610011320	Knob K299 (D)	1
MP15	8310057020	2633 window plate	1
MP16	8930060050	2633 window sheet	1
MP17	8930060060	2633 D-filter	1
MP18	8930060070	2633 jog sheet	1
MP19	8930060080	2633 A-sheet	1
MP20	8930060090	2633 key sponge	1
MP21	8930059780	2633 LCD plate	1
MP22	8930006440	Spring (F)	1
MP25	8810009220	Screw PH B0 M2 × 8 ZK	2
MP26	8810008990	Screw PH BT M2 × 10 ZK	2

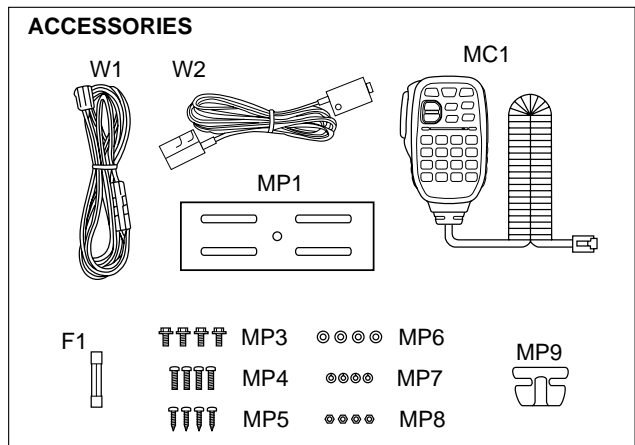

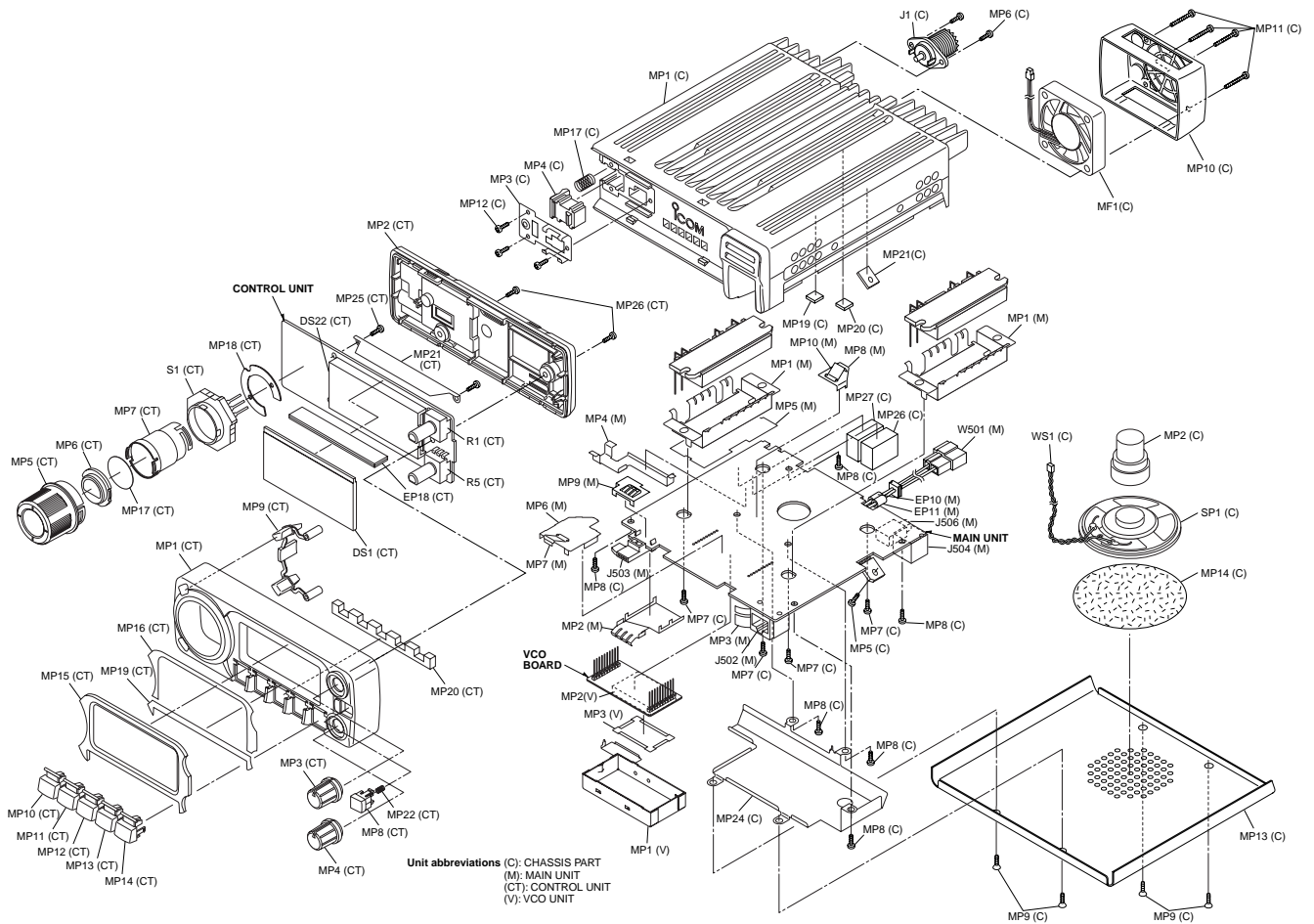

## SECTION 8 SEMI-CONDUCTOR INFORMATION

### • TRANSISTORS AND FET'S

2SA1362 GR (Symbol: AEG)	2SA1586 GR (Symbol: SG)	2SA1588 GR (Symbol: ZG)	2SA1734 (Symbol: LB)	2SB1182 TL Q (Symbol: None)
2SC2954 T1 (Symbol: QK)	2SC3357 T1 (Symbol: RK)	2SC4081 T106 R (Symbol: BR)	2SC4116 BL (Symbol: LL)	2SC4116 GR (Symbol: LG)
2SC4213 B (Symbol: AB)	2SC4215 Y (Symbol: QY)	2SC4226 T1 R25 (Symbol: R25)	2SC4403 3 TL (Symbol: LY3)	2SC5006 T1 (Symbol: 24)
2SC5008 T1 (Symbol: 44)	2SC5085 Y (Symbol: MCY)	2SC5231 C8 (Symbol: C8)	2SC5624 (Symbol: VH-)	2SJ144 GR (Symbol: VG)
3SK299 T1 U73 (Symbol: U73)	UMG9N TL (Symbol: G9)	UN9113J (Symbol: 6C)	UN9114J (Symbol: 6D)	UN9115J (Symbol: 6E)
UN911NJ (Symbol: EW)	UN9210J (Symbol: 8L)	UN9213J (Symbol: 8C)	UN921NJ (Symbol: EX)	XP1115 (Symbol: 9L)
XP4601 (Symbol: 5C)	XP6501 AB (Symbol: 5N)			

### • DIODES

1SS355 (Symbol: A)	1SS362 (Symbol: C3)	1SS400 (Symbol: A)	1SV286 (Symbol: T7)	1SV305 (Symbol: TV)
1SV308 (Symbol: TX)	DA221 TL (Symbol: K)	DAN222TL (Symbol: N)	DSA3A1 (Color: Green)	HVC136 (Symbol: P6)
HVC350B (Symbol: B0)	HVC375B (Symbol: B8)	HVC376B (Symbol: B9)	HVU131 TRF (Symbol: P1)	MA25077 (Symbol: S)
MA2S30400 L (Symbol: K)	MA2S728 (Symbol: B)	MA2SV0550 L (Symbol: 3A)	MA742 (Symbol: M1U)	MA8047 M (Symbol: 4-7)
MA8062 L (Symbol: 6_2)	MA8068 M (Symbol: 6-8)	RD20E B2 (Symbol: 20 B2)	UM9401F (Symbol: none)	

## SECTION 9 BOARD LAYOUTS

### 9-1 CONTROL UNIT • TOP VIEW

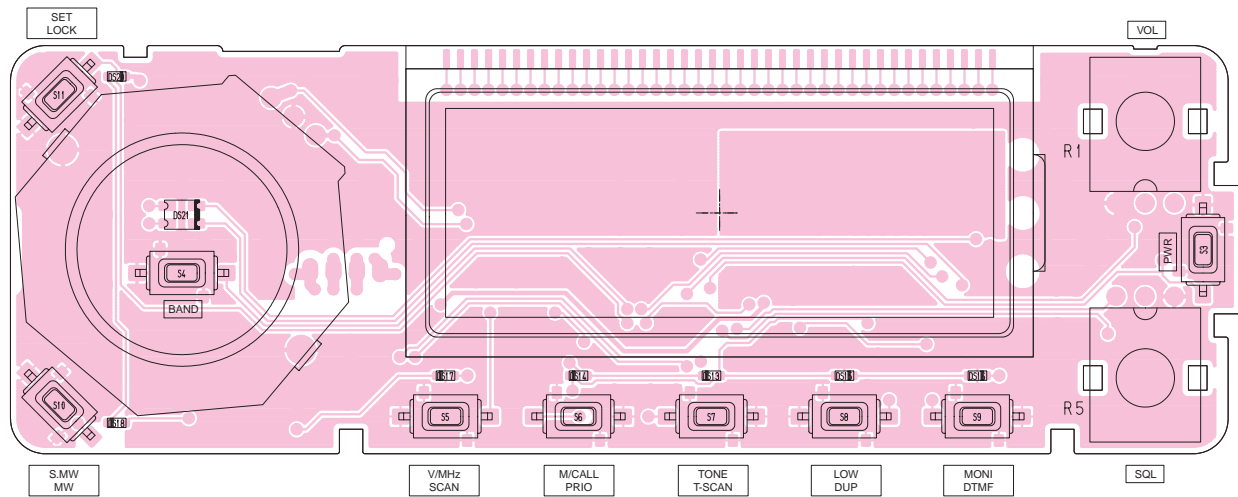

• BOTTOM VIEW (CONTROL UNIT)

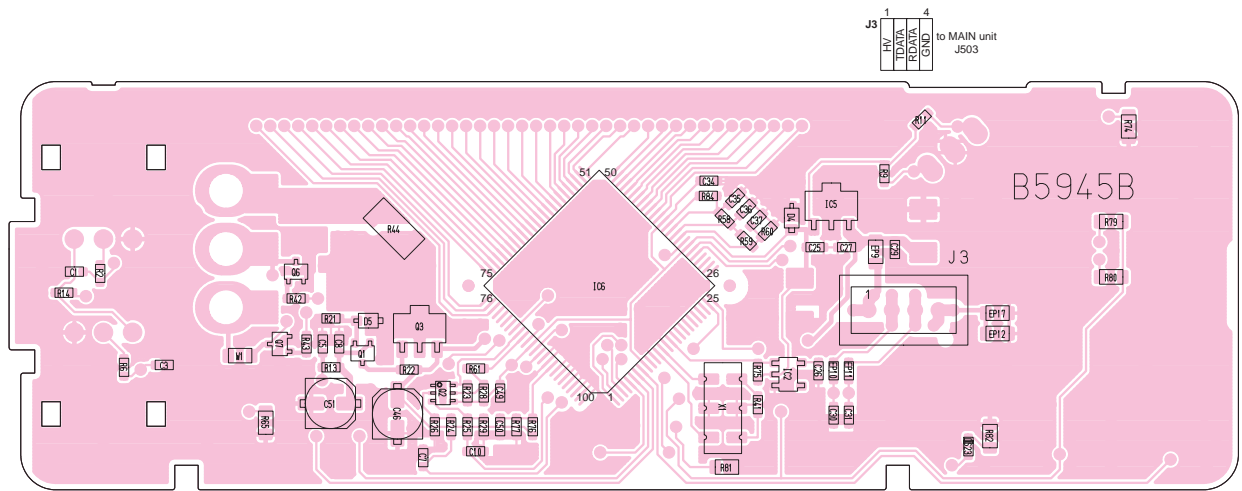

**9-2 MAIN UNIT**  
• TOP VIEW

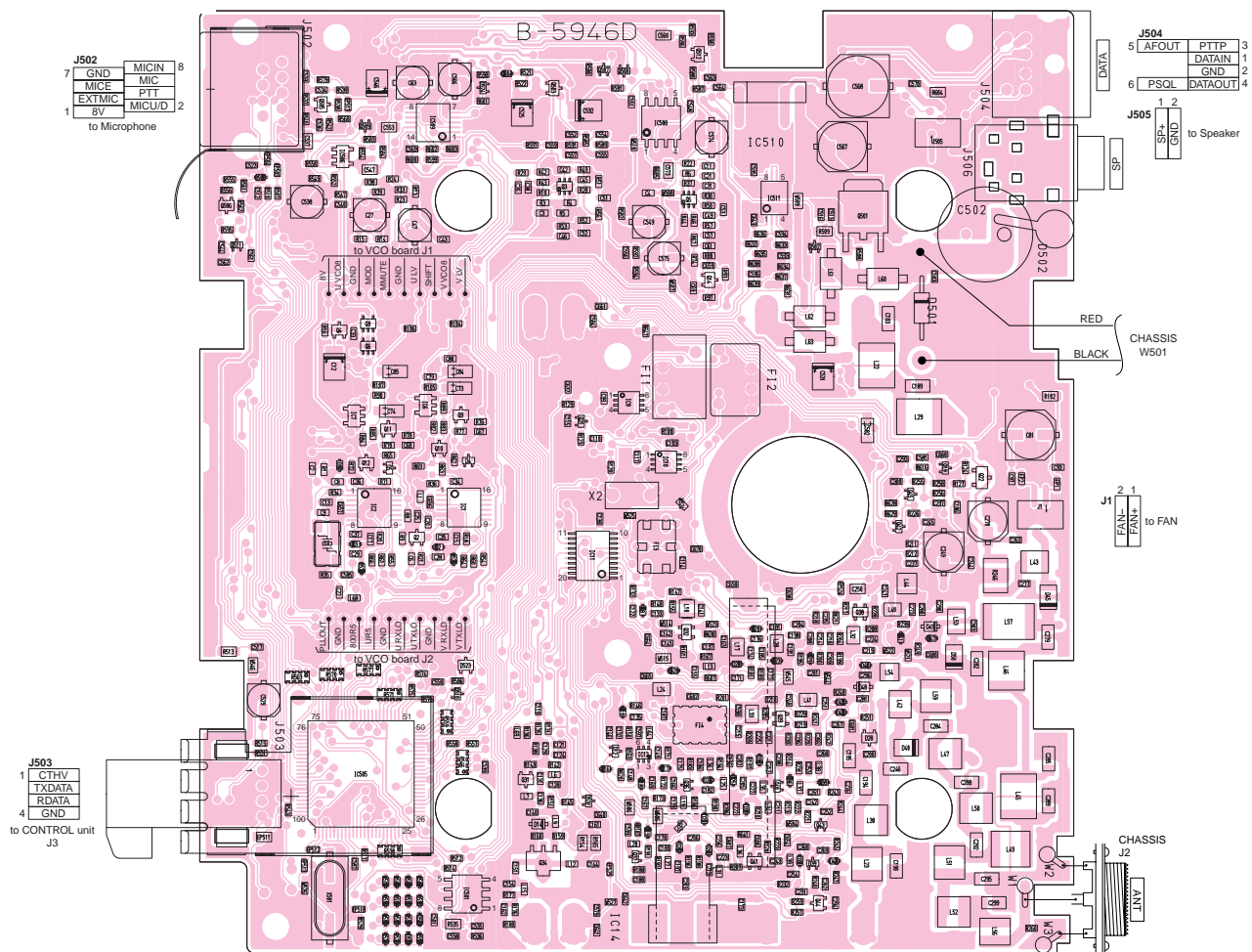

• BOTTOM VIEW (MAIN UNIT)

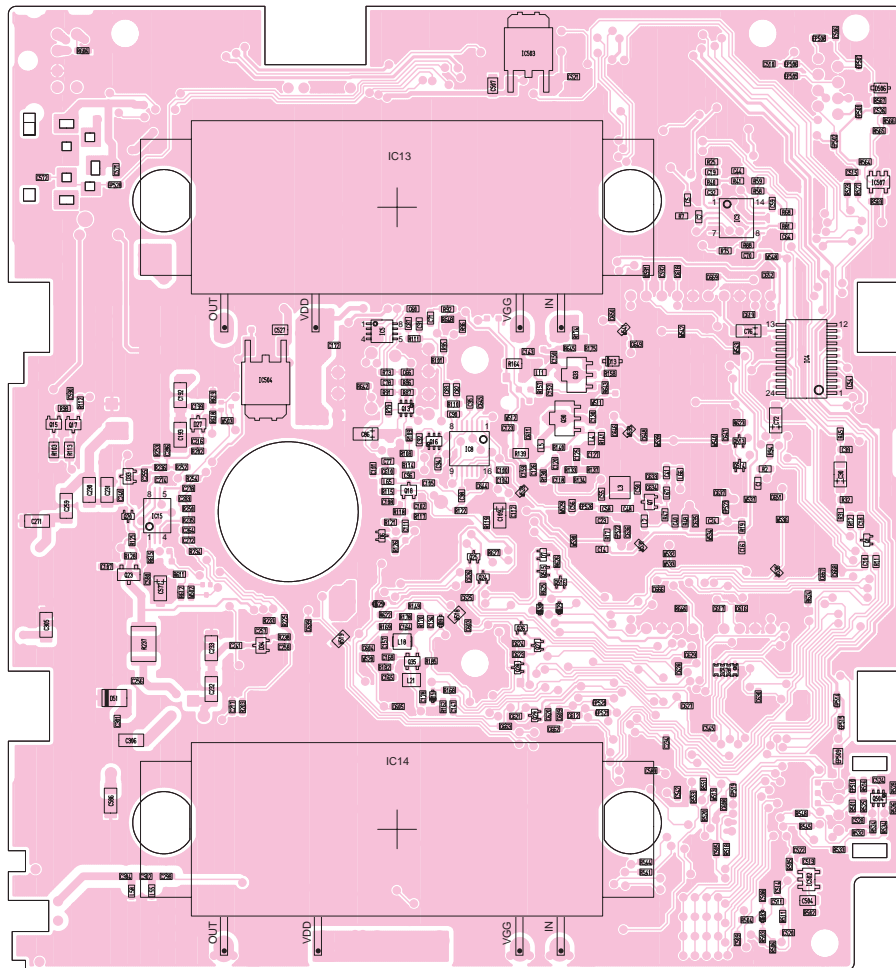



• BOTTOM VIEW (VCO BOARD)

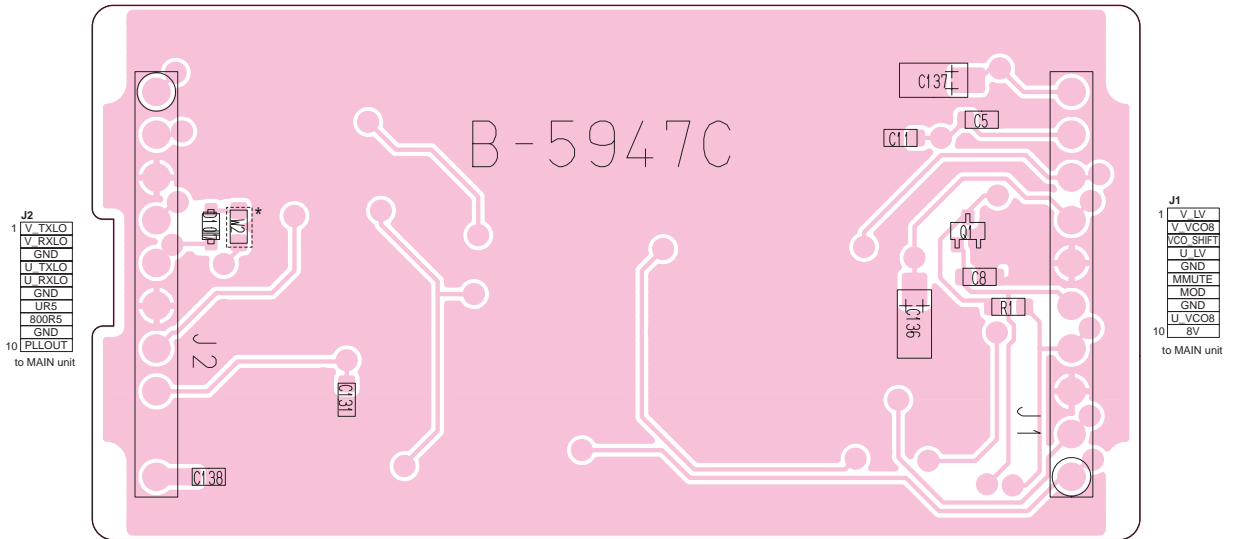

\*Mounted R128 in place of W2 ([USA], [E208] only)

# SECTION 10 BLOCK DIAGRAM

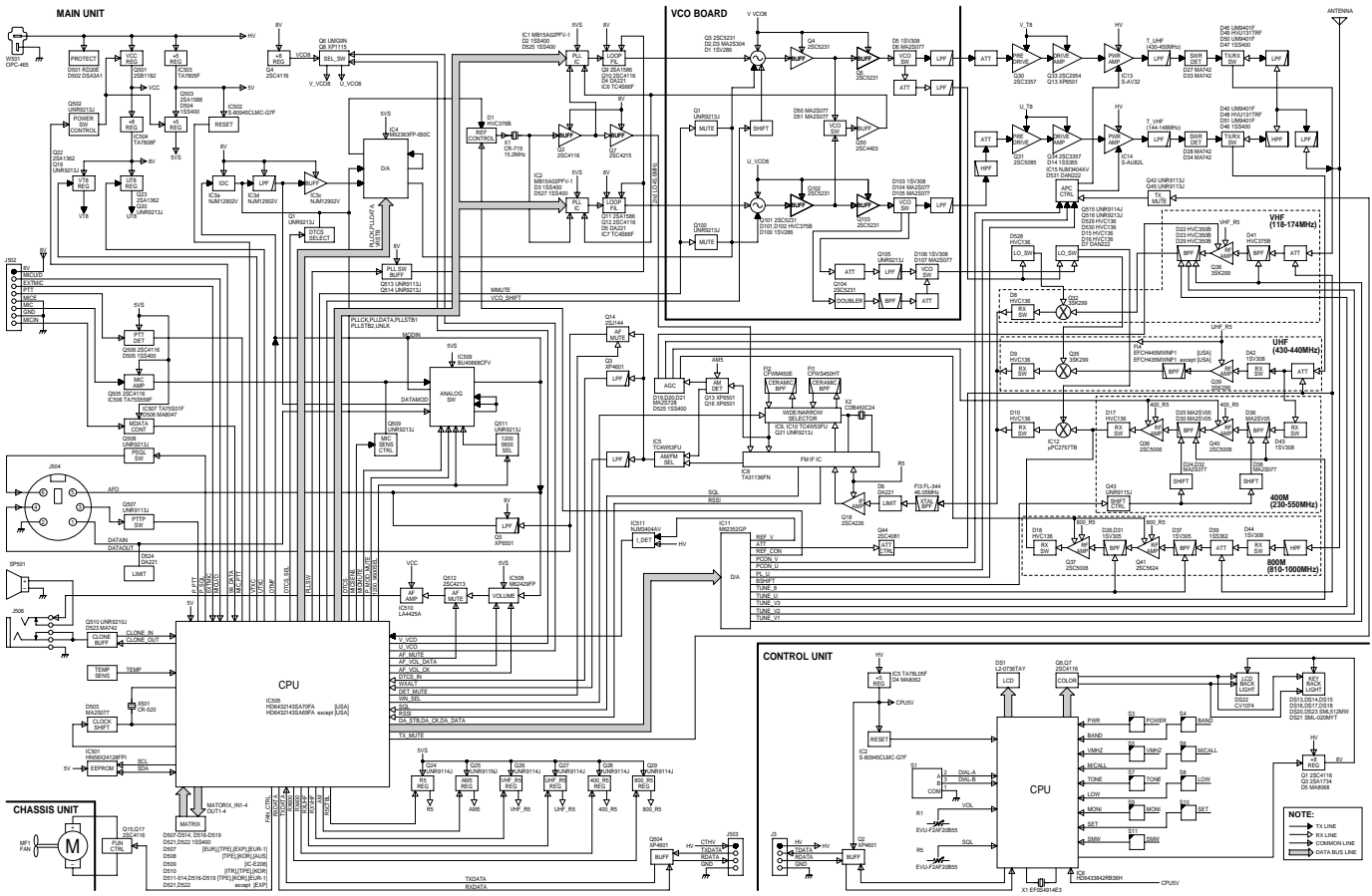

# SECTION 11 VOLTAGE DIAGRAMS

## 11-1 CONTROL UNIT

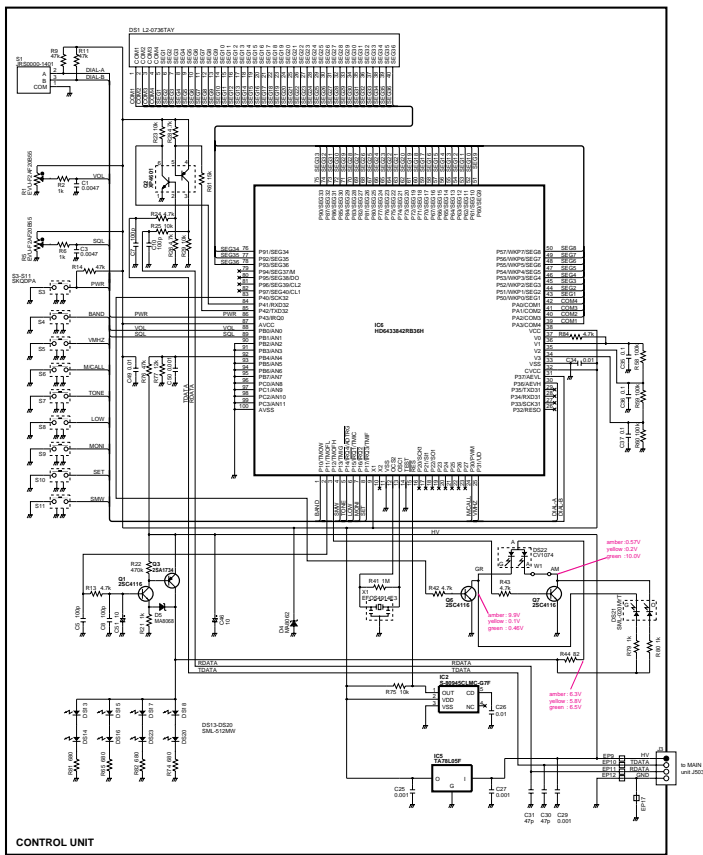

11-2 MAIN UNIT

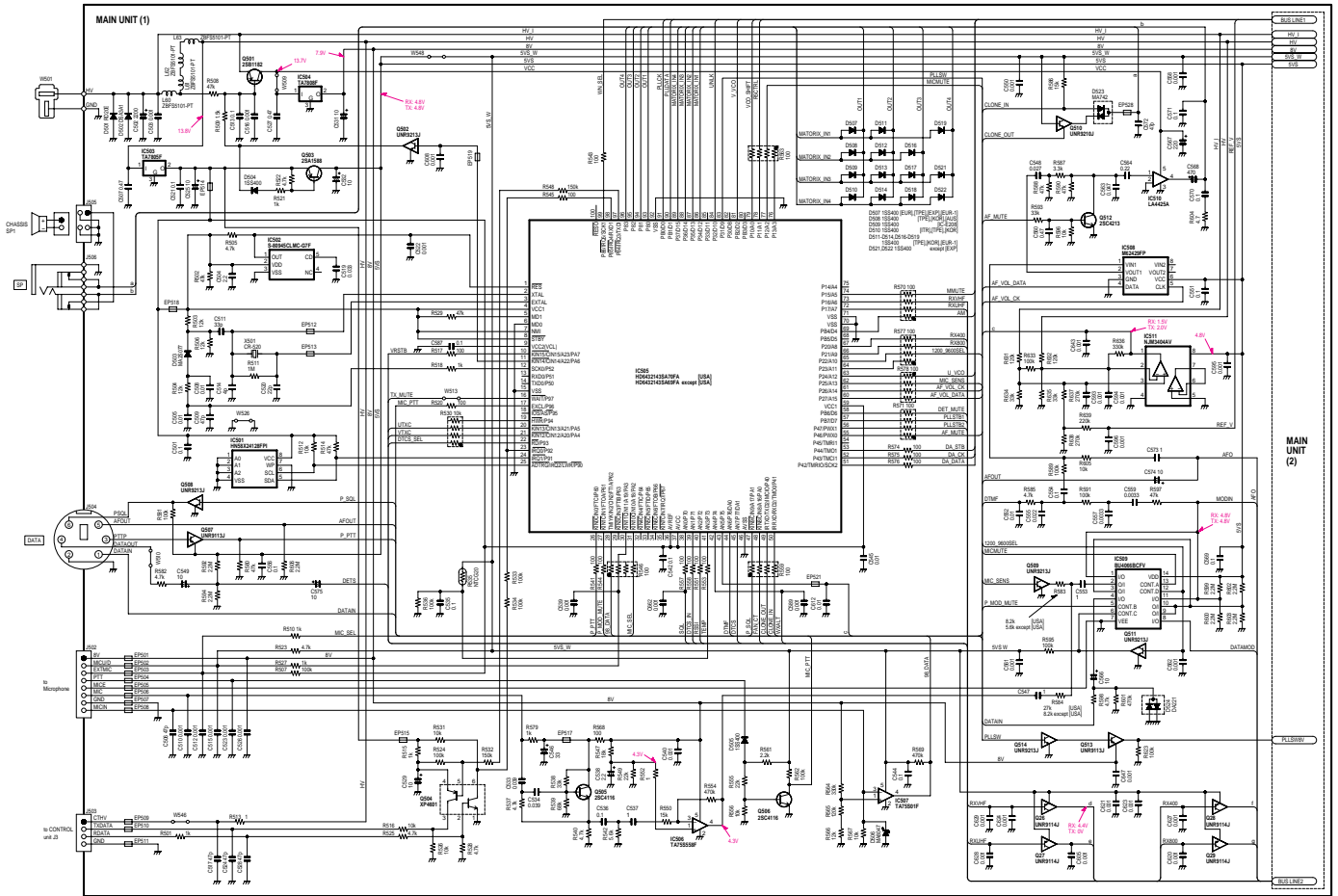

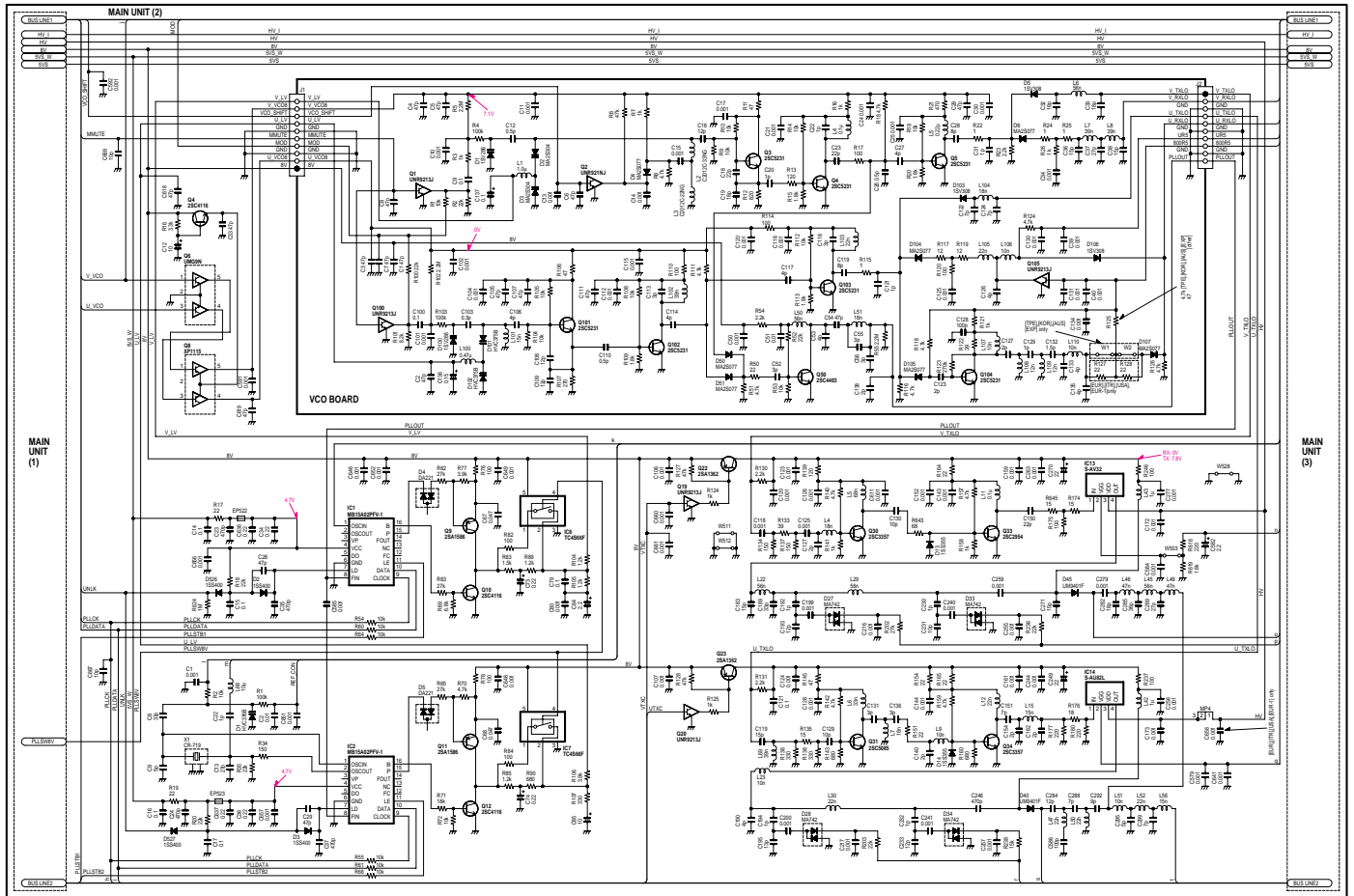

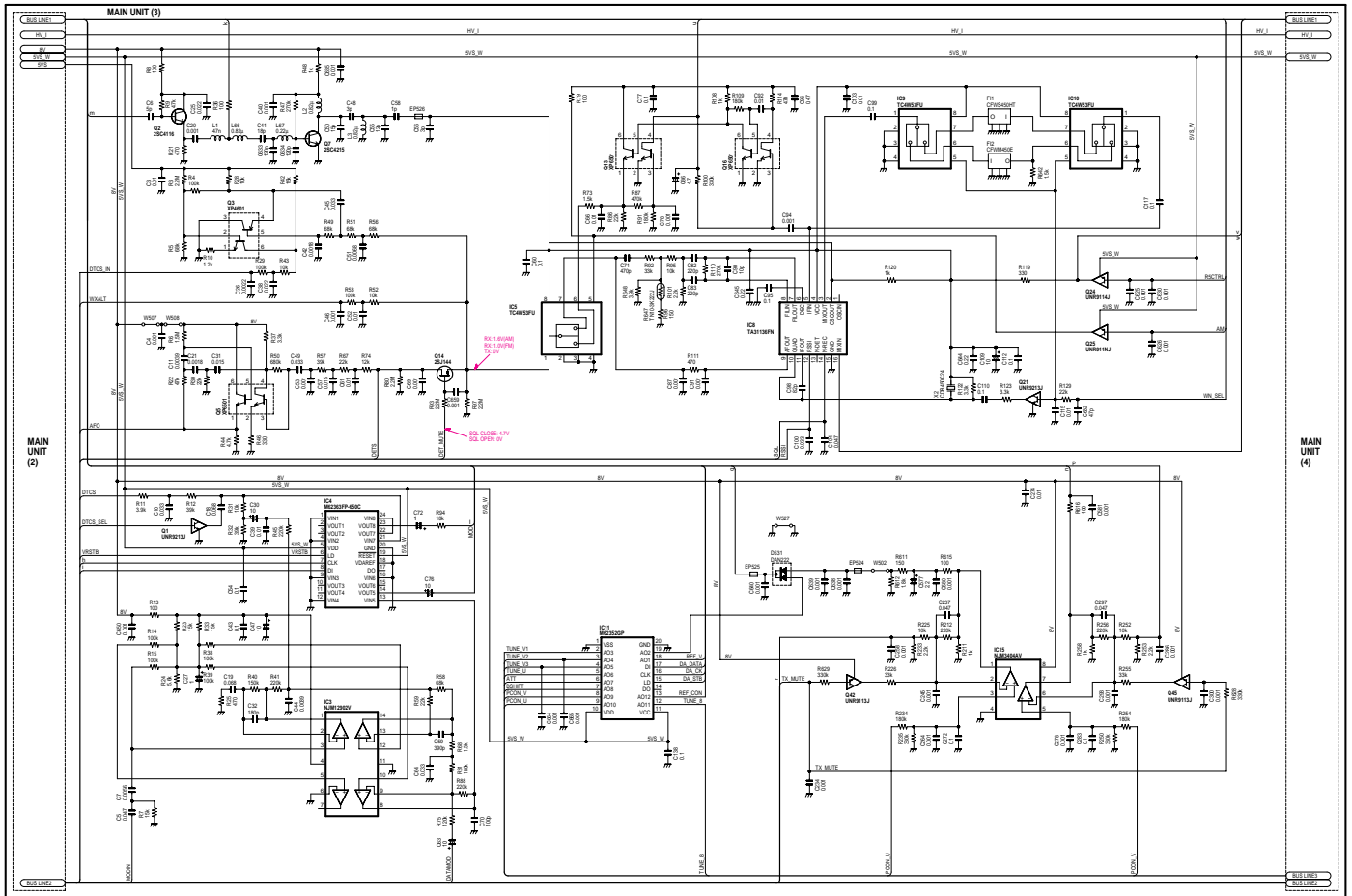



## Icom Inc.

1-1-32, Kamiminami, Hirano-ku, Osaka 547-0003, Japan  
Phone : 06 6793 5302  
Fax : 06 6793 0013  
URL : <http://www.icom.co.jp/world/index.html>

### Icom America Inc.

<Corporate Headquarters>  
2380 116th Avenue N.E., Bellevue, WA 98004, U.S.A.  
Phone : (425) 454-8155 Fax : (425) 454-1509  
URL : <http://www.icomamerica.com>  
<Customer Service>  
Phone : (425) 454-7619

### Icom Canada

Glenwood Centre #150-6165  
Highway 17 Delta, B.C., V4K 5B8, Canada  
Phone : (604) 952-4266 Fax : (604) 952-0090  
URL : <http://www.icomcanada.com>

### Icom (Australia) Pty. Ltd.

A.B.N. 88 006 092 575  
290-294 Albert Street, Brunswick, Victoria, 3056, Australia  
Phone : 03 9387 0666 Fax : 03 9387 0022  
URL : <http://www.icom.net.au>

### Icom New Zealand

146A Harris Road, East Tamaki,  
Auckland, New Zealand  
Phone : 09 274 4062 Fax : 09 274 4708  
URL : <http://www.icom.co.nz>

### Beijing Icom Ltd.

1305, Wanshang Plaza, Shijingshan Road, Beijing China  
Phone : (010) 6866 6337 Fax : (010) 6866 3553  
URL : <http://www.bjicom.com>

### Icom (Europe) GmbH

Communication Equipment  
Himmelgeister Str. 100, D-40225 Düsseldorf, Germany  
Phone : 0211 346047 Fax : 0211 333639  
URL : <http://www.icomeurope.com>

### Icom Spain S.L

C/ta. de Gracia a Manresa Km. 14,750  
08190 Sant Cugat del Valles Barcelona, SPAIN  
Phone : (93) 590 26 70 Fax : (93) 589 04 46  
URL : <http://www.icomspain.com>

### Icom (UK) Ltd.

Unit 9, Sea St., Herne Bay, Kent, CT6 8LD, U.K.  
Phone : 01227 741741 Fax : 01227 741742  
URL : <http://www.icomuk.co.uk>

### Icom France S.a

Zac de la Plaine, 1, Rue Brindejonc des Moulinais  
BP 5804, 31505 Toulouse Cedex, France  
Phone : (33) 5 61 36 03 03 Fax : (33) 5 61 36 03 00  
URL : <http://www.icom-france.com>

### Asia Icom Inc.

6F No. 68, Sec. 1 Cheng-Teh Road, Taipei, Taiwan, R.O.C.  
Phone : (02) 2559 1899 Fax : (02) 2559 1874  
URL : <http://www.asia-icom.com>

**Count on us!**

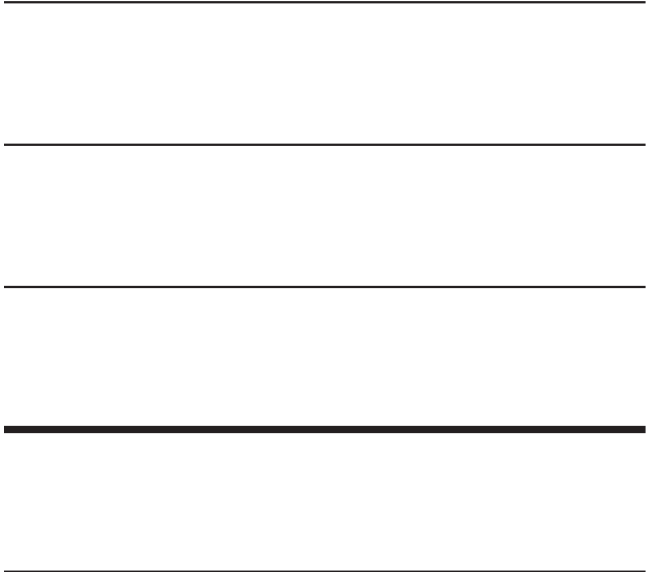

**Icom Inc.**

1-1-32, Kamiminami, Hirano-ku, Osaka 547-0003, Japan

S-14001HZ-C1  
© 2003 Icom Inc.

# Other ManualsLib Projects



[www.manualslib.com](http://www.manualslib.com)



[www.manualslib.de](http://www.manualslib.de)



[www.manualslib.es](http://www.manualslib.es)



[www.manualslib.fr](http://www.manualslib.fr)



[www.manualslib.nl](http://www.manualslib.nl)



[www.manualslib.mx](http://www.manualslib.mx)



[www.manualslib.tech](http://www.manualslib.tech) 30+ Languages